

Volute Casing Pumps

self-priming

ULN 32-125 . . . 125-250



TECHNICAL DATA

Output:	max. 300 m ³ /h
Head:	max. 95 m
Suction head:	max. 5 m (cold water)
Speed:	max. 3000 rpm
Temperature:	max. 120 °C
Casing pressure:	PN 16/10 ¹⁾
Shaft sealing:	standard mechanical seal
Flange connections:	DIN 2501 PN 1610 ¹⁾
Sense of rotation:	clockwise when seen on the pump from the drive

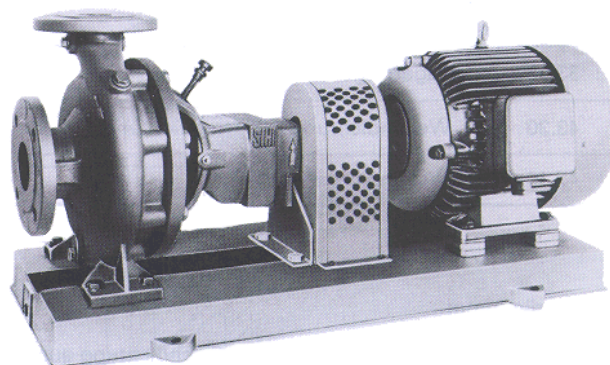

APPLICATION

The **self-priming** volute casing pumps according to DIN 24255 of the series ULN are applied when it is necessary to suck in and to handle without problems and automatically, pure resp. turbid not aggressive liquids which do not contain any solids. So they are suitable for:

- drinking water supply for communities
- general water supply in agriculture, business and industry
- irrigation and drainage
- sprinkling
- pumping of condensate
- charge and discharge of fuels and oils

Please observe: the max. geodetical suction height amounts to 5 m, provided that the necessary pressure corresponding to NPSH is not exceeded.

DESIGN

Horizontal, self-priming single stage volume casing pumps with dimensions and nominal outputs accord. to DIN 24255/EN 733 in back pull out construction.

The back pull out construction allows the demounting of the complete bearing unit towards the drive side so that it is not necessary to detach the pump casing out of the pipings. On applying a coupling with dismounting piece it will be superfluous to detach the motor.

The programme consists of 27 sizes with 4 suction sizes and needs only 2 shaft units on applying the mechanical assembly technique.

Within a shaft unit, shaft sealing, impeller fastening and bearing cover are exchangeable.

The side channel suction stage is arranged at the drive side of the volute casing. It is connected in parallel to the liquid pumping stage and works according to the sucking through principle.

¹⁾ up from construction size 100-200 10 bar

CONSTRUCTION

Casing pressure:

Max. 16/10¹⁾ bar from -40 °C to + 120 °C
Intermediate values can be interpolated.

Please observe:

Technical rules and safety regulations.

Casing pressure = positive suction pressure + zero delivery head

Position of branches:

Suction branch directed axially, discharge branch directed radially upwards.

Flanges:

The flanges correspond to DIN 2533/2532 PN 16/10¹⁾.
Flange design drilled accord. to ANSI 150 is possible.

Speed:

n = 1450 rpm; Designation of this construction type: A-
n = 2900 rpm; Designation of this construction type: B-

Bearing:

Two greased antifriction bearings. First grease filling will be made in the factory.. Designation of this construction type: ·B
As special design oil lubrication is possible.

Sense of rotation:

Clockwise when seen on the pump from the drive.

Shaft sealing:

The shaft sealing is made by a standard mechanical seal.

Designation AAЕ: uncooled, not balanced single standard mechanical seal, flushed from internal source, O-rings Perbunan.
Temperature range: -40 °C up to +120 °C

Designation AA1: as per AAЕ, but O-rings Viton.
Temperature range: -40 °C up to +140 °C

Material design

Item	COMPONENTS	MATERIAL DESIGN		
		0A	0C	3B
10.20 10.90, 11.40 16.10	volute casing stage casing casing cover	GG-25		G-CuSn 10
21.00	shaft	X 20 Cr 13		X 5 Cr Ni Mo 18 10
23.00	impeller	GG 25	G-Cu Sn 10	
23.50	vane wheel impeller	So Ms die-pressed		chrom-plate
33.00	bearing bracket	GG-25		
43.30	shaft sealing mechanical seal	X 22 Cr Ni 17 / carbon, Perbunan		X 22 Cr Ni 17 / carbon, Viton
47.10	shaft sealing casing	GG-25		G-Cu Sn 10

Casing seal:

For casing sealing a flat type seal of special paper is used. Designation of this construction type: 2

Drive / Speed and co-ordination of the suction stages:

Drive by commercial electric motors, construction type IM B3.

Drive by V-belt is admitted up to 1,5 kW drive power. On request, drive by Diesel engines or gasoline motors.

Suction stage	I			II			II			IV		
Size	32-125 32-250 40-250 65-125	32-160 40-125 50-125	32-200 40-200 50-160	50-200 65-200	50-250 80-160	65-160	65-250 100-200	80-200 100-250	80-250	32-250 50-250 65-315 80-315 100-315	40-250 50-315 80-200 100-200 125-250	40-315 65-250 80-250 100-250
Additional drive power kW	0,3			0,9			2,2			0,7		
Speed rpm	2900						1450					
Max. speed rpm	300						1800					
Characteristic design	B •						A •					

The suction stages have been co-ordinated to the different construction sizes in such a manner that an optimal time at an economical drive power will be attained. On selecting of the motor size for the pump unit this constant drive power is to be considered.

The max. speed of $n = 3000$ rpm resp. $n = 1800$ rpm results from the admitted peripheral speed of GG-impellers of 40 m/s resp. from the max. pumping pressure of 10 bar, as well as from the admitted stress of the suction stage.

General comments:

For self-priming multistage segmental type pumps we refer to the series **TKH** and **TLH**

Technical documentation about these programmes will be readily supplied on request.

Sectional drawing and nomenclature

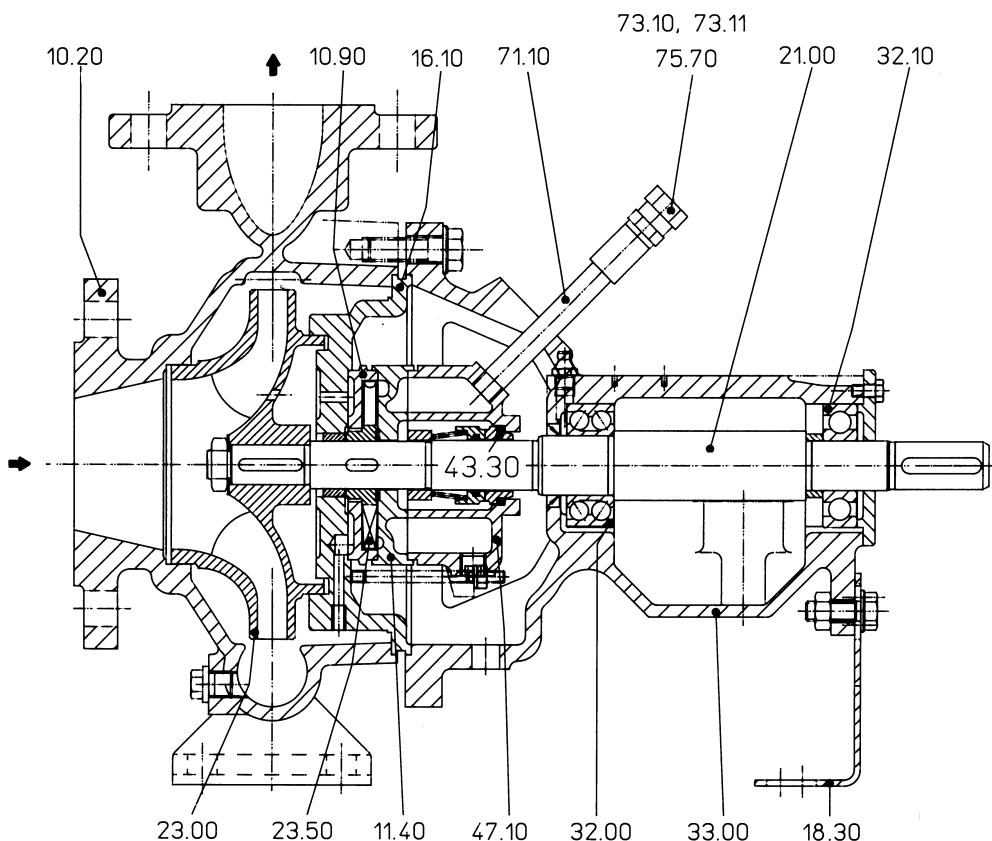

10.20	volute casing	23.00	impeller	43.30	mechanical seal
10.90, 11.40	stage casing	23.50	vane wheel impeller	47.10	shaft sealing casing
16.10	casing cover	32.00	inclined ball bearing	71.10	ventilation line
18.30	support foot	32.10	grooved ball bearing	73.10, 73.11	pipe union with orifice plate
21.00	shaft	33.00	bearing bracket	75.70	orifice plate

Advices for the installation

The pipeline on suction side has to be installed as shown, above pump centre, so that sufficient quantity of liquid for the self suction procedure is available.

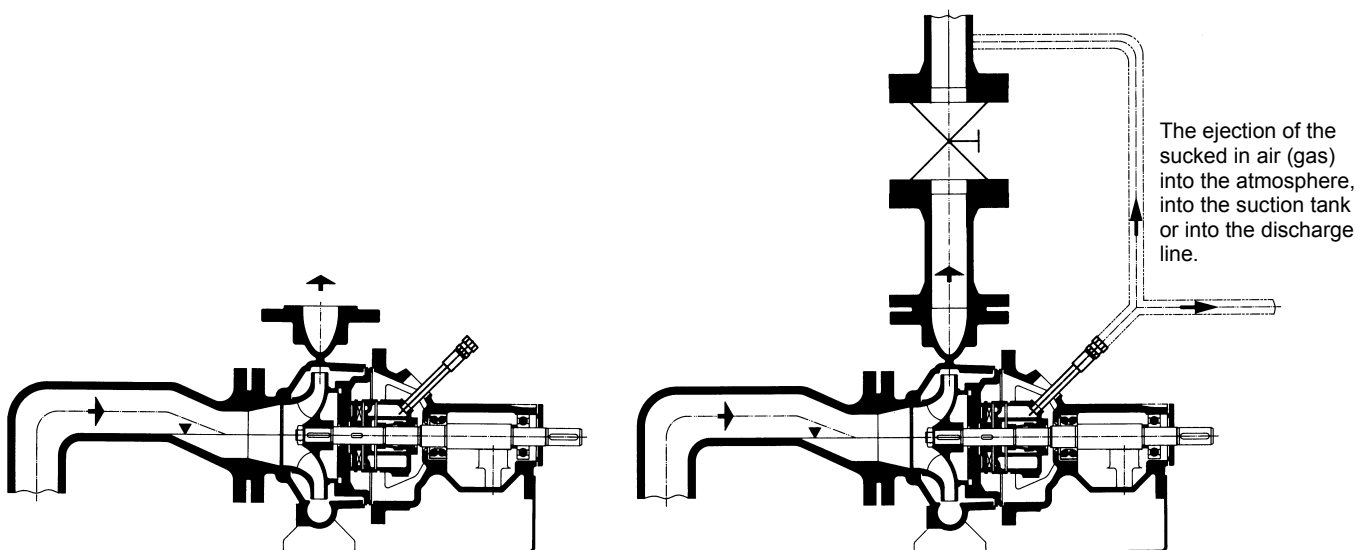

Performance graph

50 Hz
n = 2900 rpm

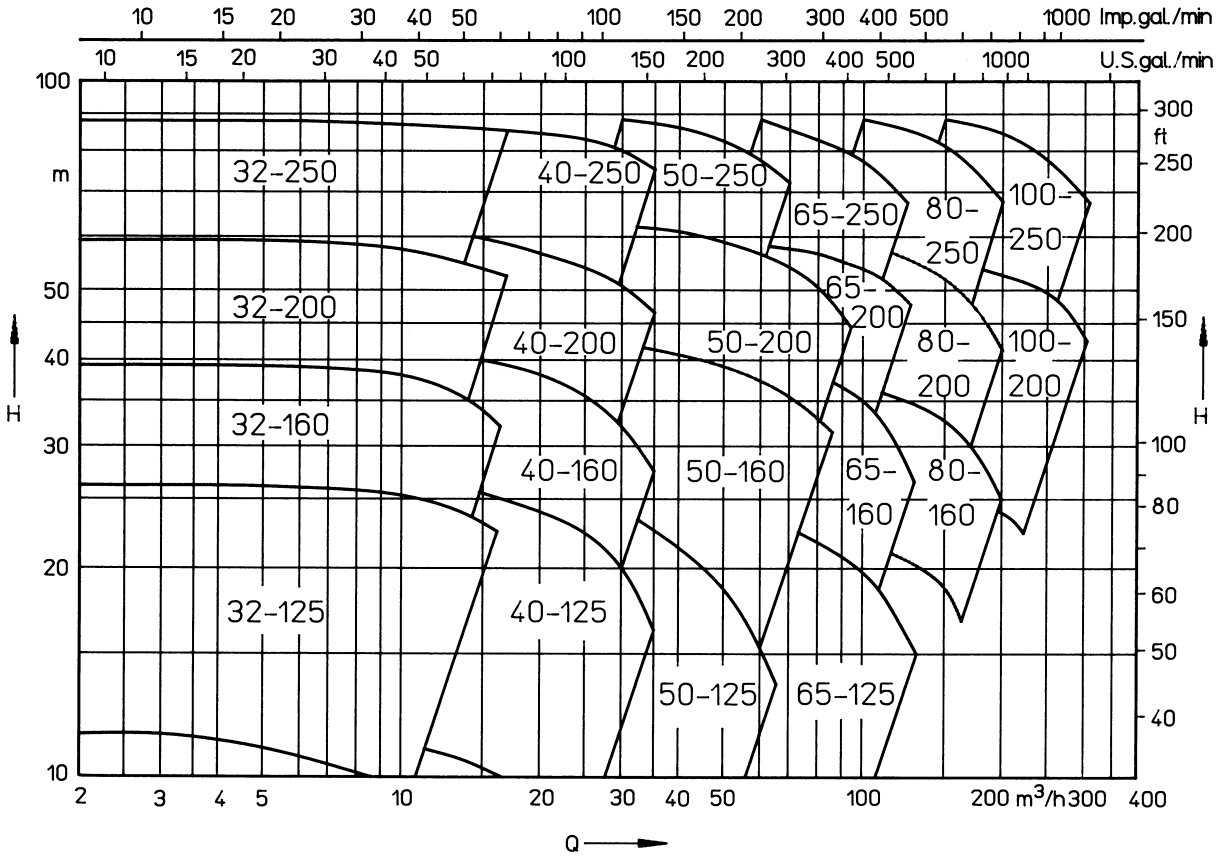

n = 1450 rpm

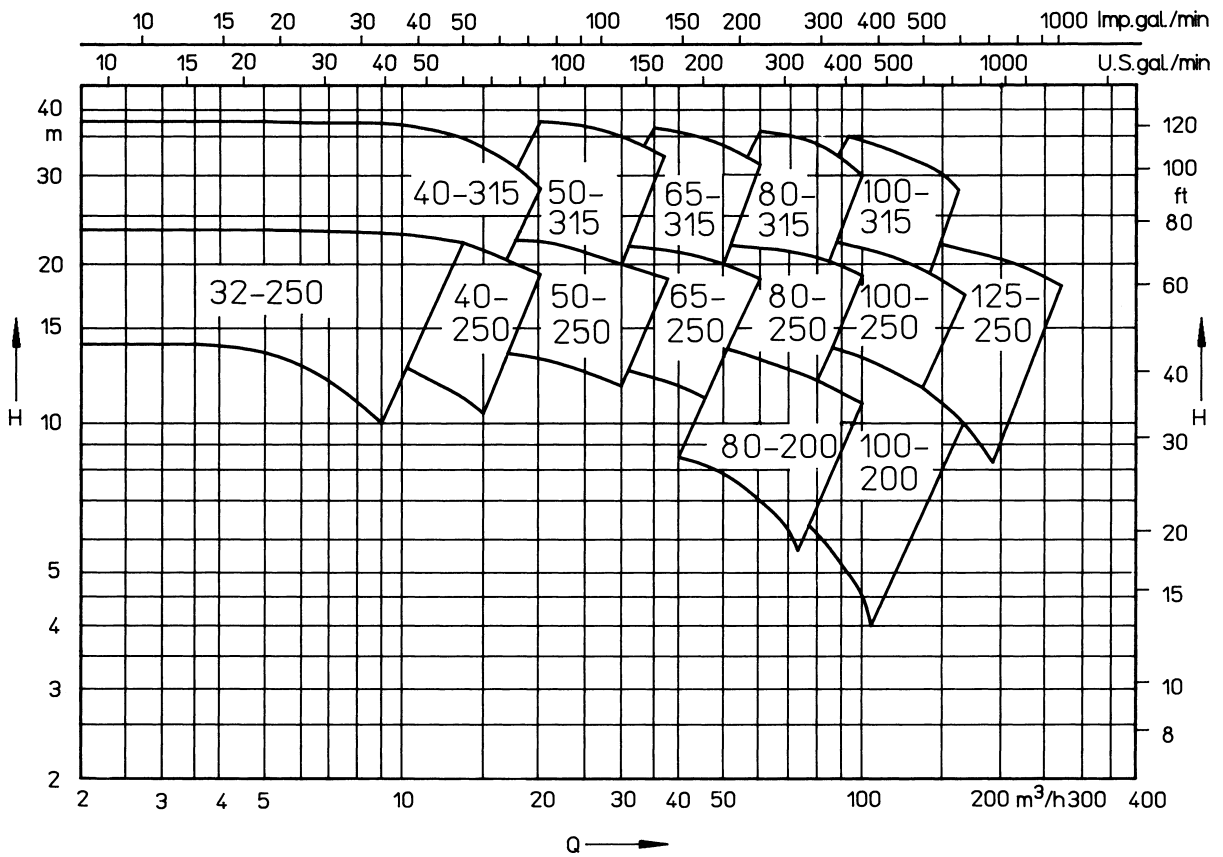

Characteristic curves

n = 2900 rpm

Attention: On selecting the motors, the constant drive power of the pertinent suction stage has to be added to the drive values determined out of the characteristic curves

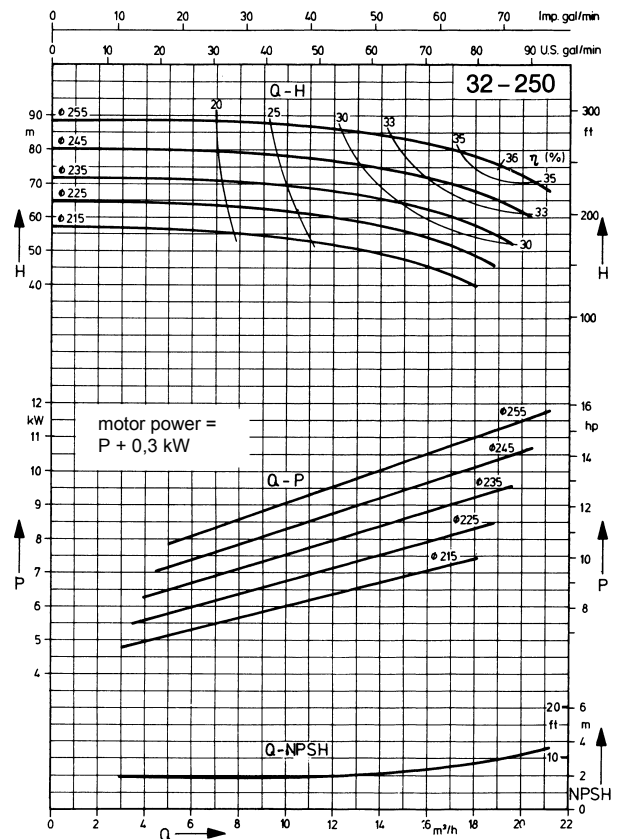
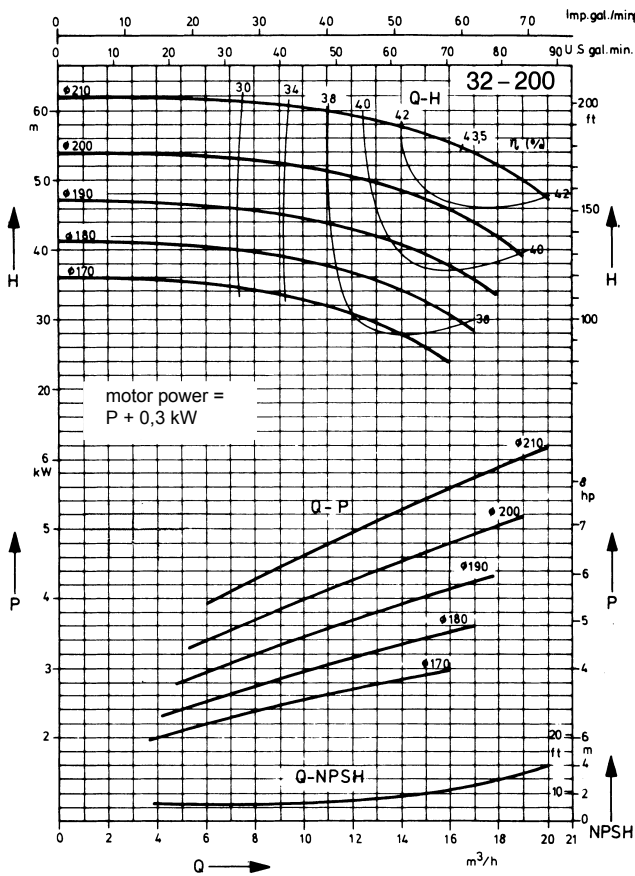
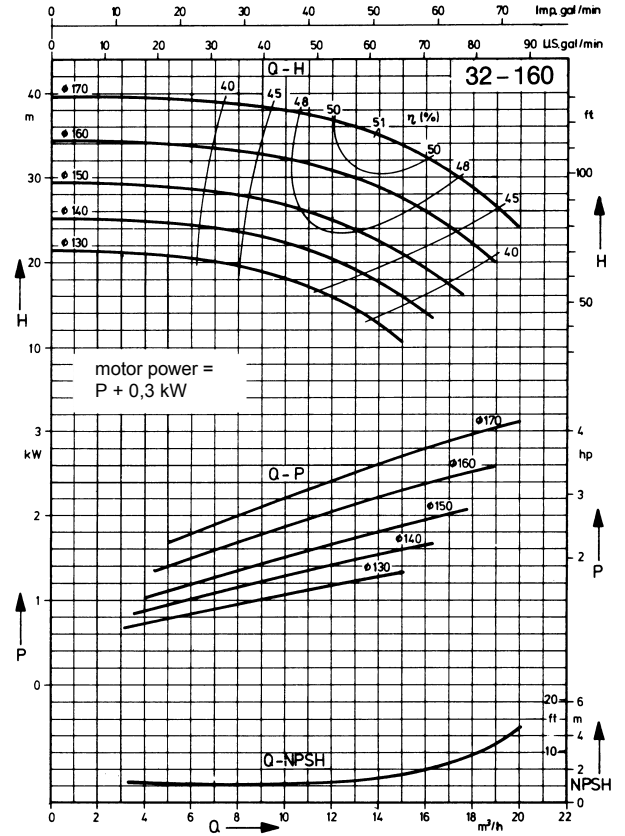
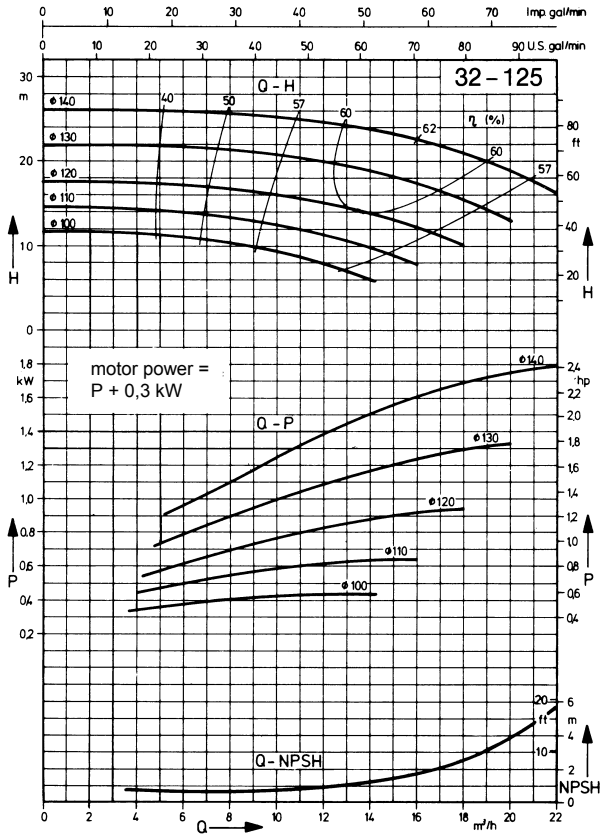

Characteristic curves

$n = 2900 \text{ rpm}$

Attention: On selecting the motors, the constant drive power of the pertinent suction stage has to be added to the drive values determined out of the characteristic curves

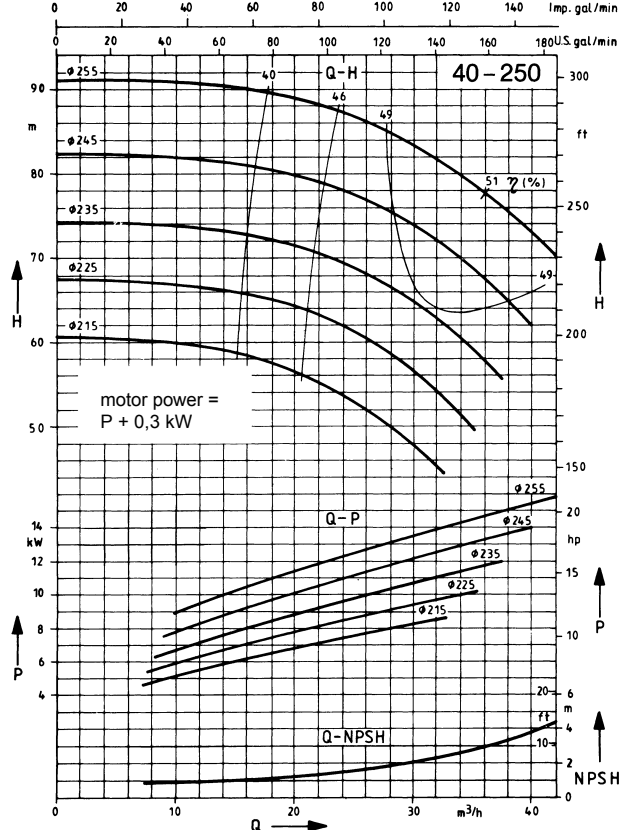
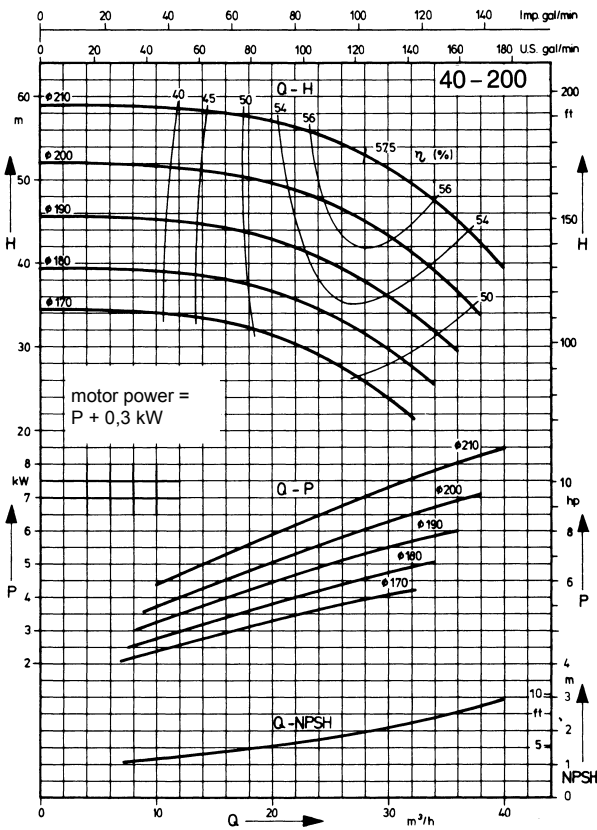
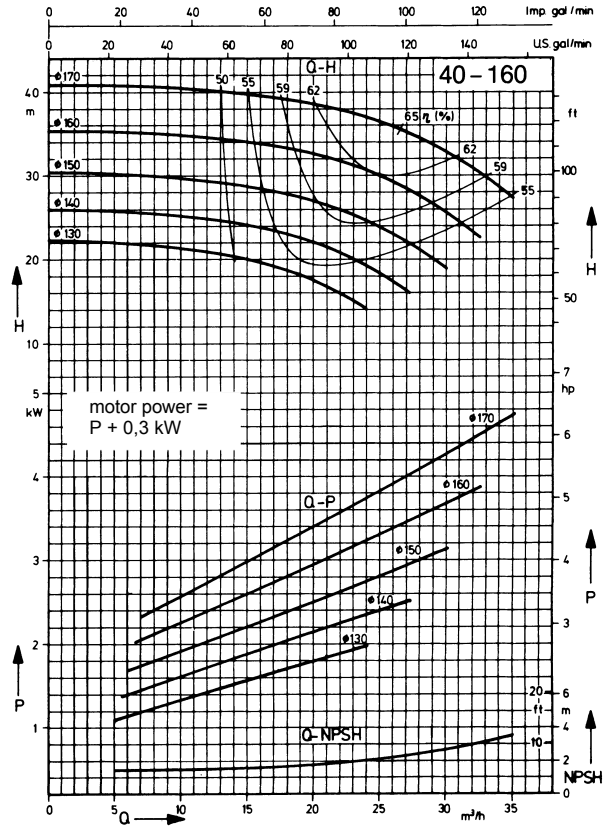
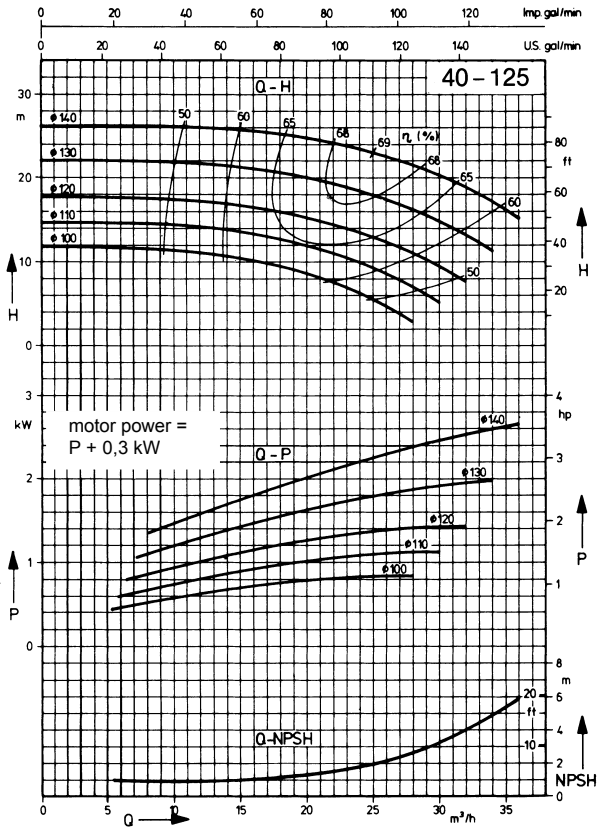

Characteristic curves

n = 2900 rpm

Attention: On selecting the motors, the constant drive power of the pertinent suction stage has to be added to the drive values determined out of the characteristic curves

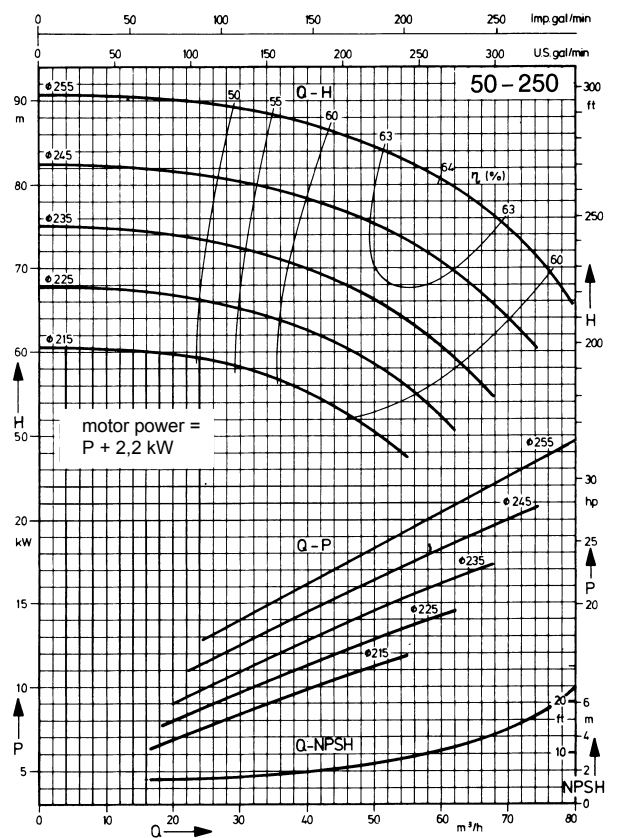
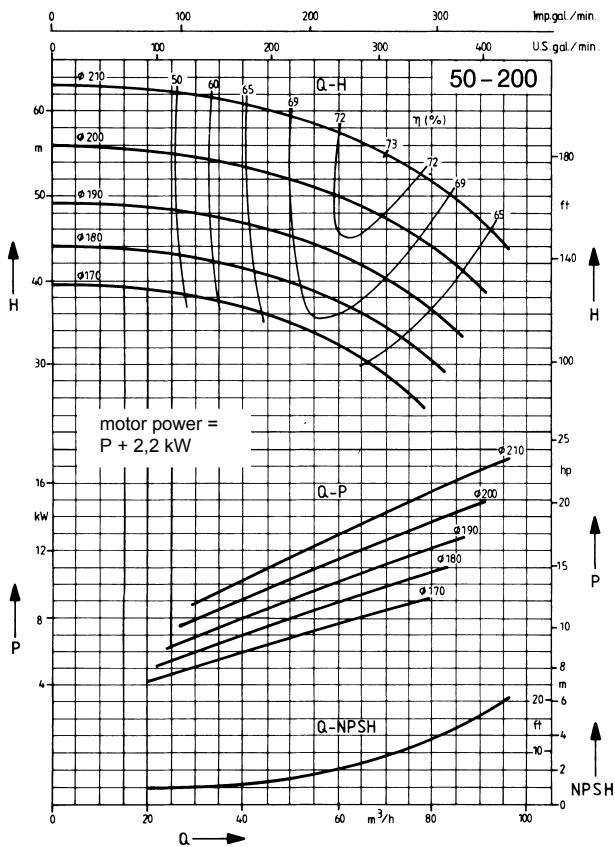
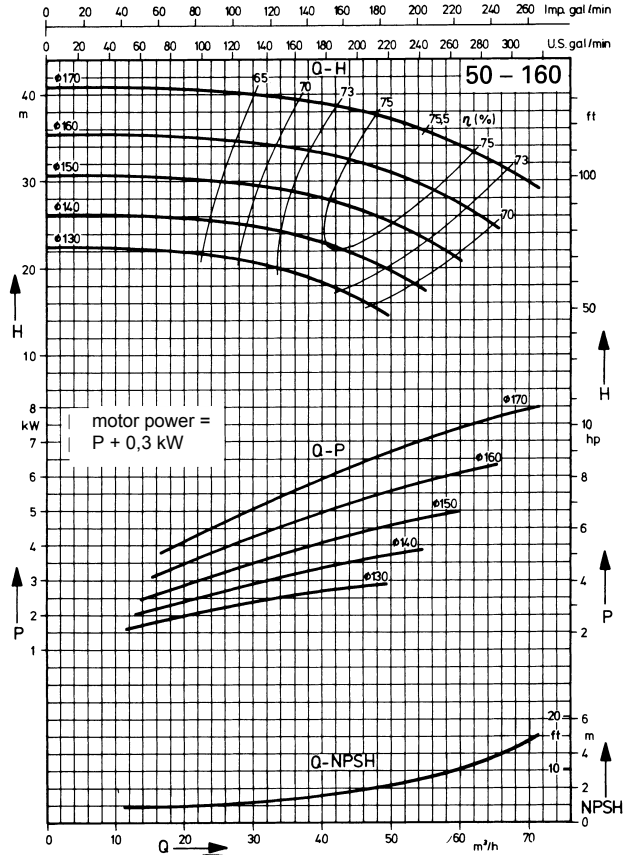
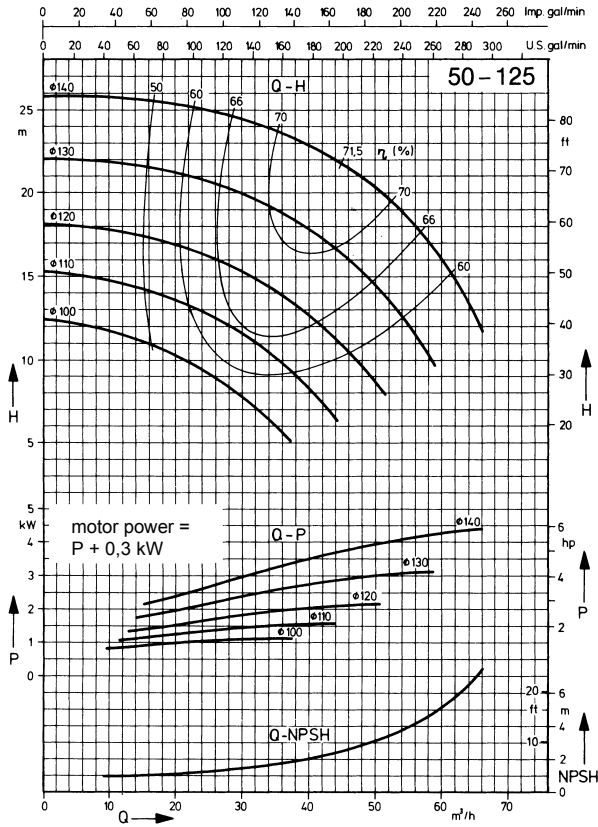

Characteristic curves

n = 2900 rpm

Attention: On selecting the motors, the constant drive power of the pertinent suction stage has to be added to the drive values determined out of the characteristic curves

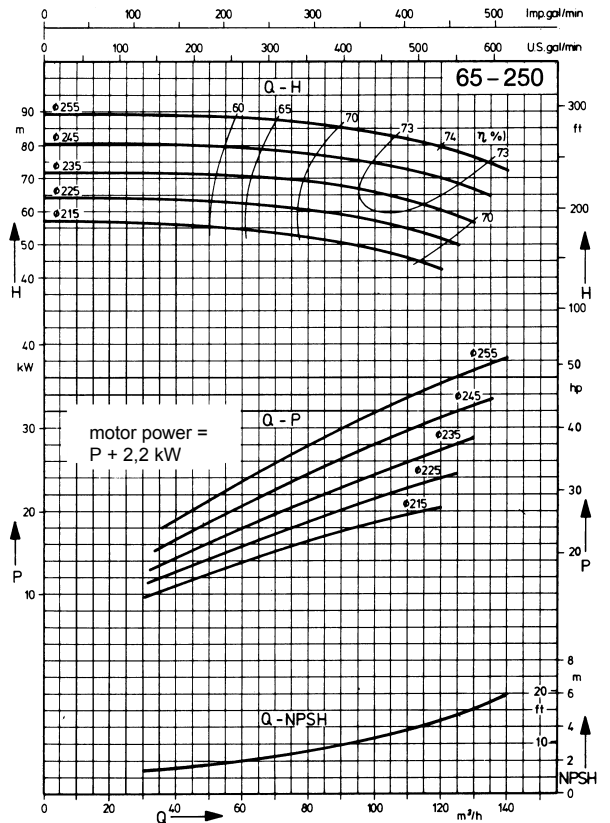
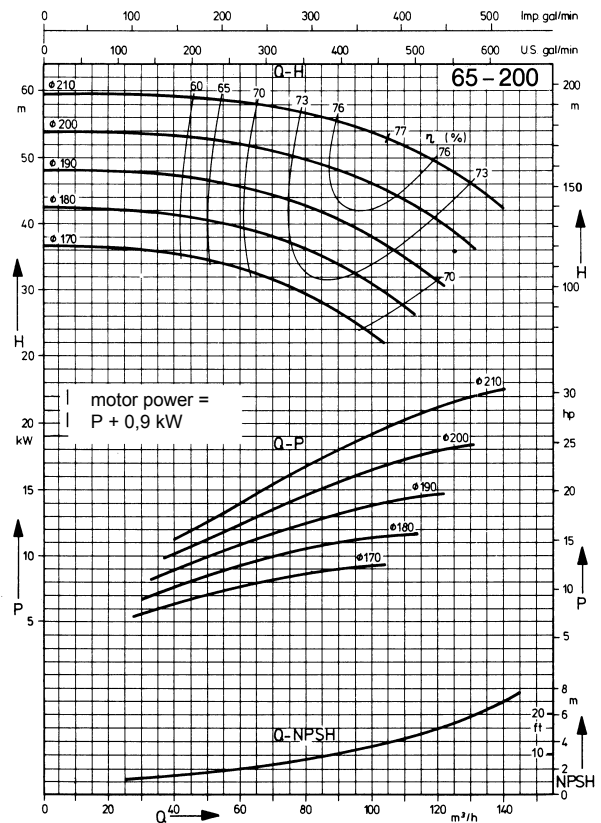
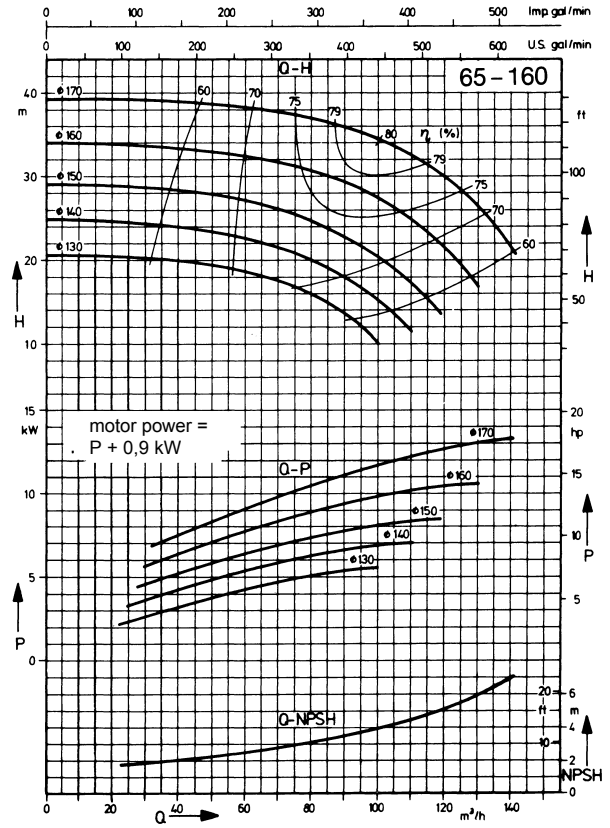
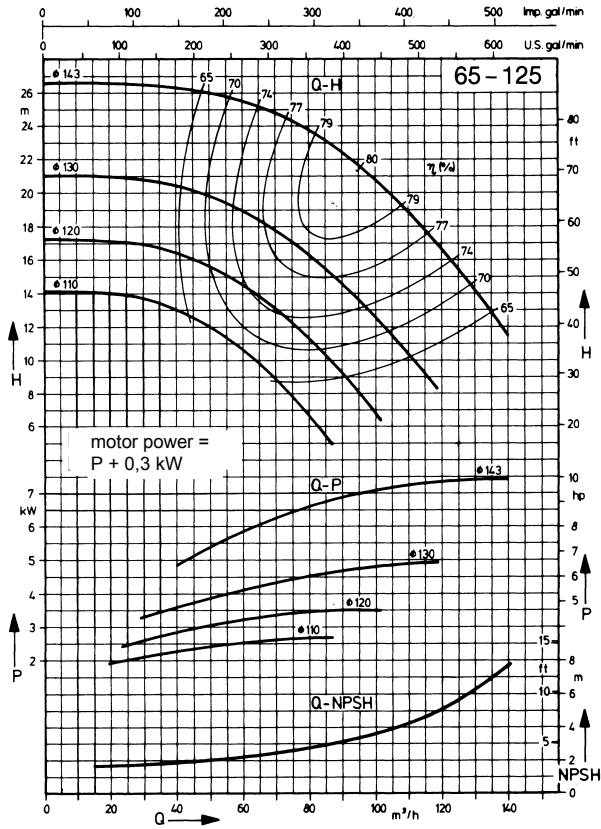

Characteristic curves

n = 2900 rpm

Attention: On selecting the motors, the constant drive power of the pertinent suction stage has to be added to the drive values determined out of the characteristic curves

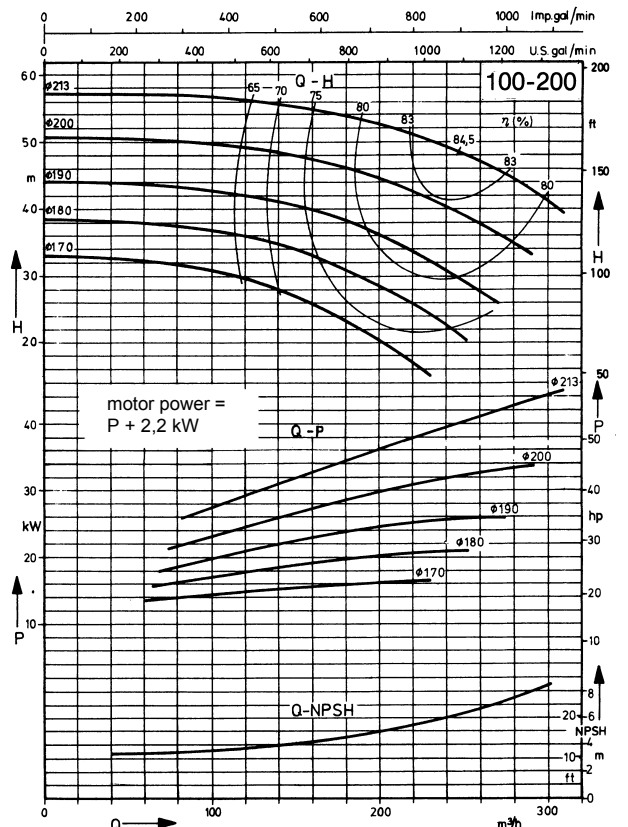
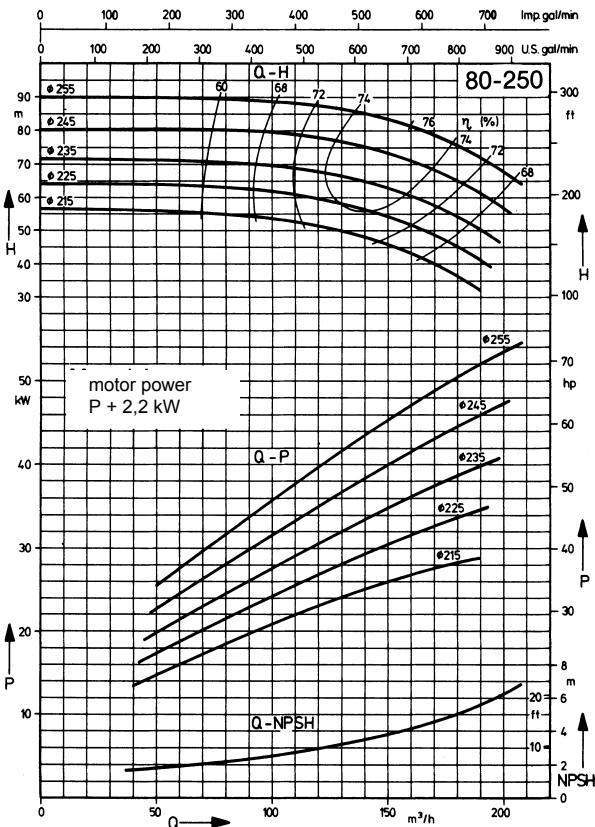
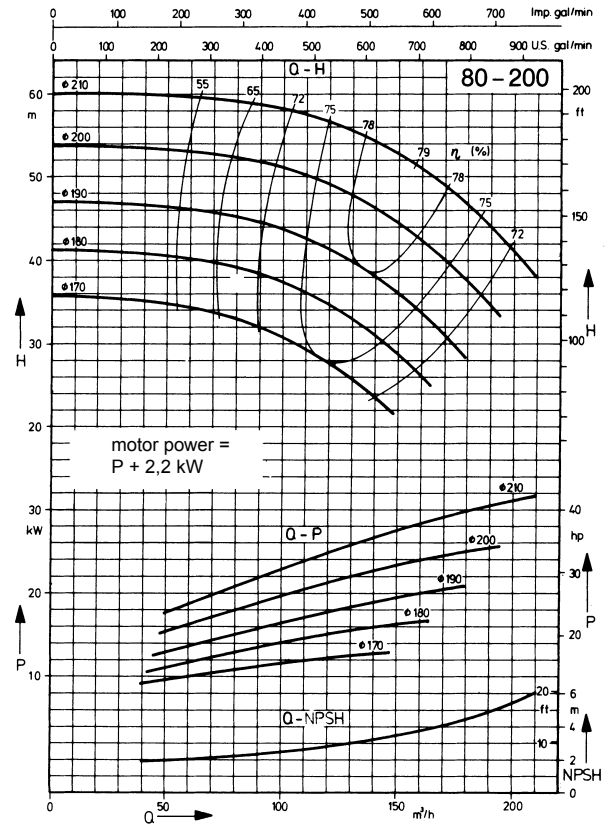
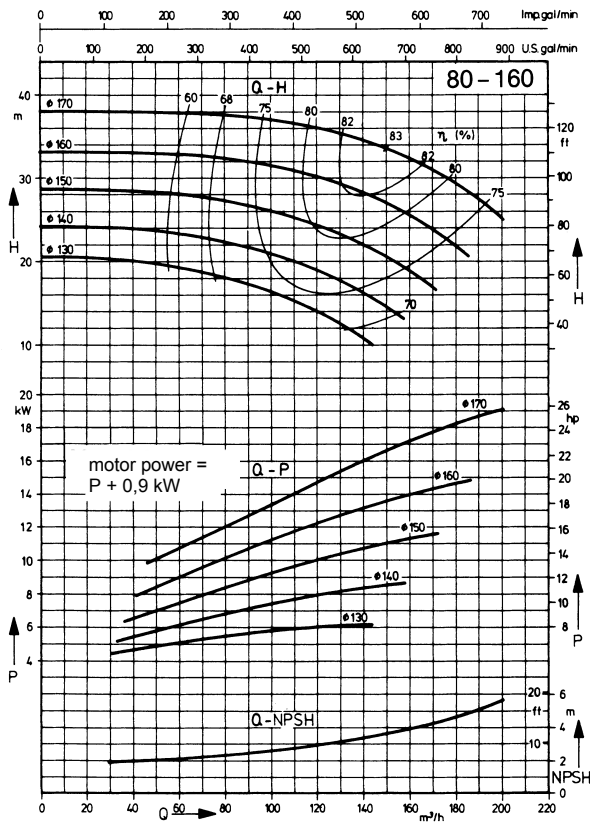

Characteristic curves

n = 2900 rpm

Attention: On selecting the motors, the constant drive power of the pertinent suction stage has to be added to the drive values determined out of the characteristic curves

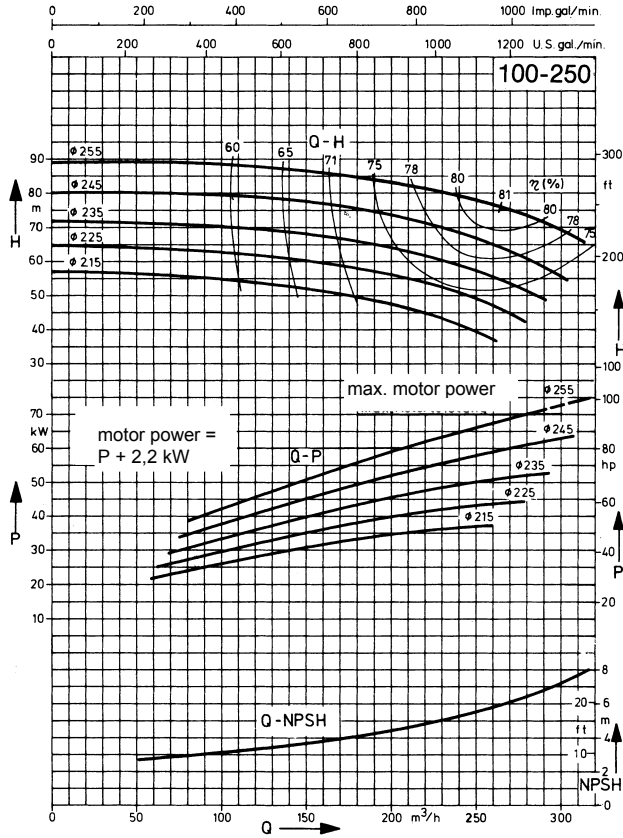

n = 1450 rpm

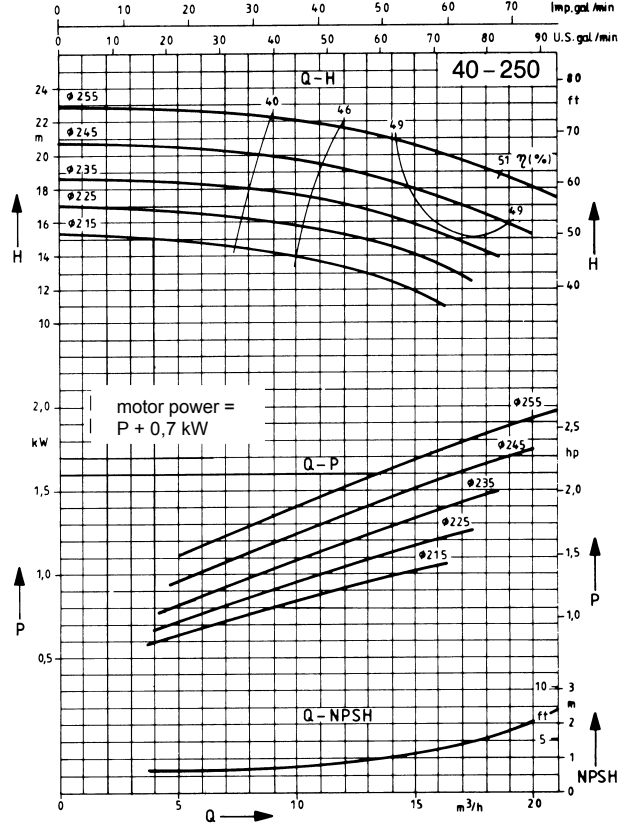
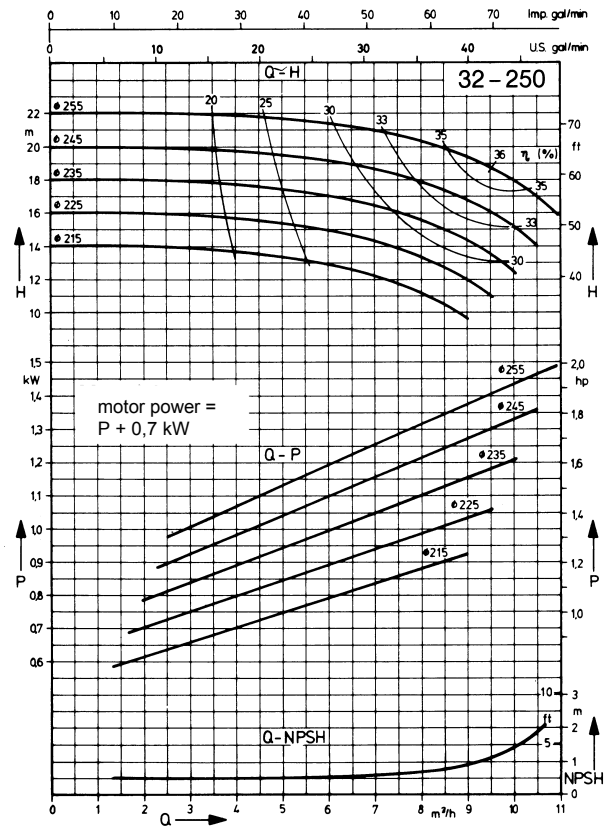

Characteristic curves

n = 1450 rpm

Attention: On selecting the motors, the constant drive power of the pertinent suction stage has to be added to the drive values determined out of the characteristic curves

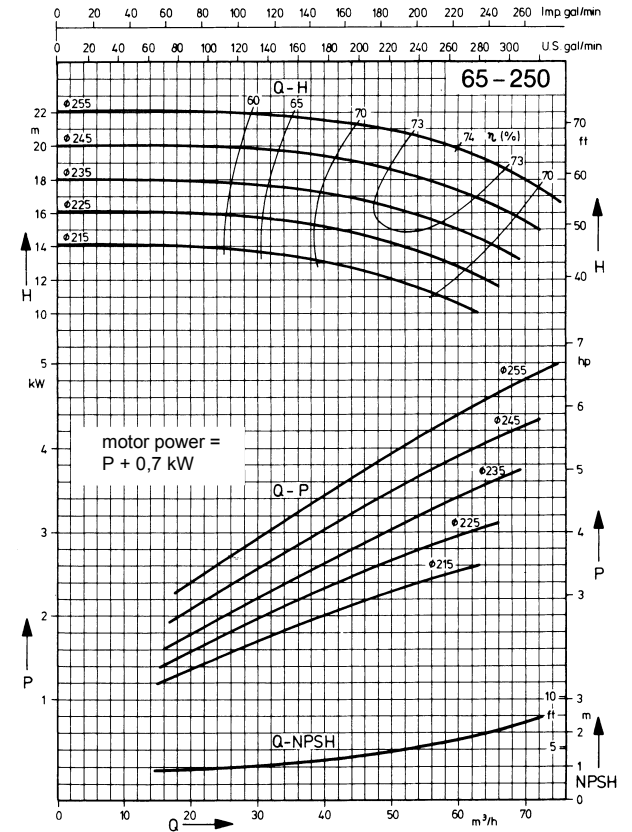
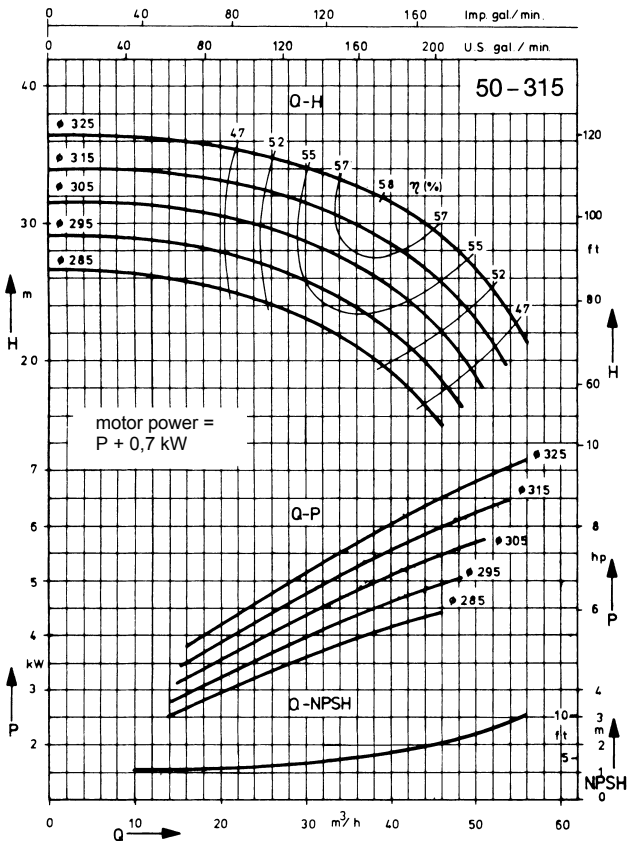
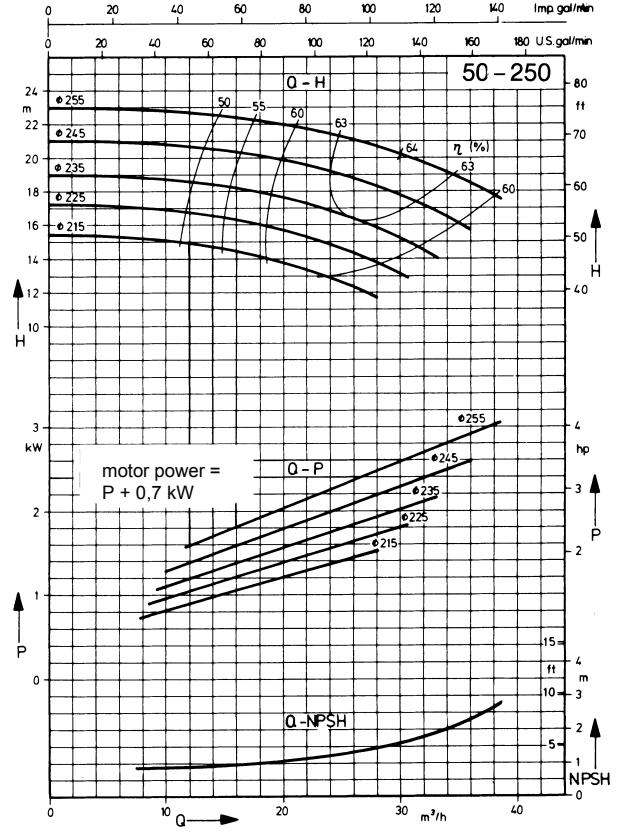
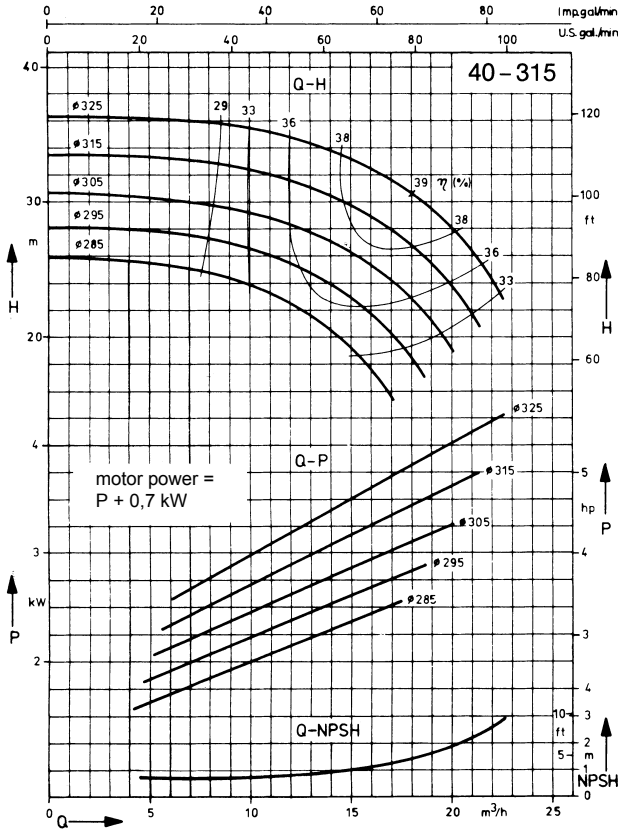

Characteristic curves

n = 1450 rpm

Attention: On selecting the motors, the constant drive power of the pertinent suction stage has to be added to the drive values determined out of the characteristic curves

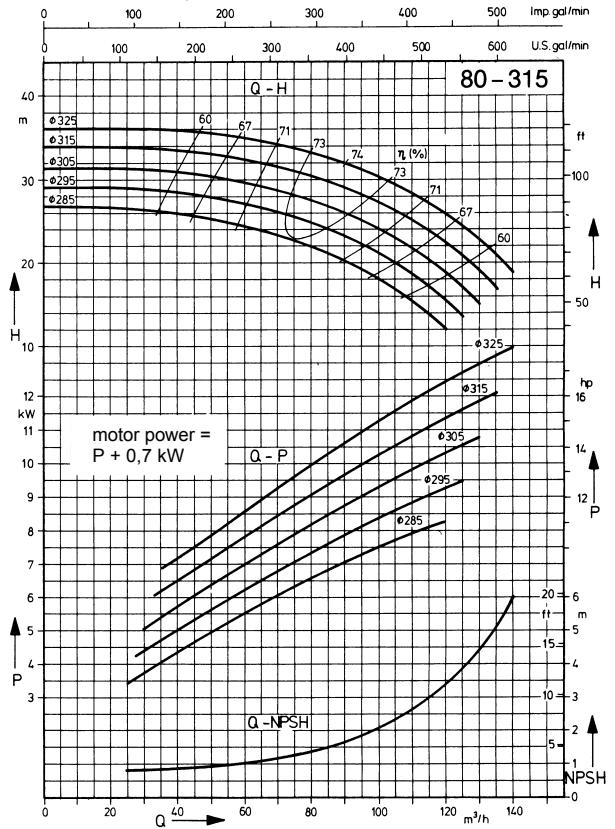
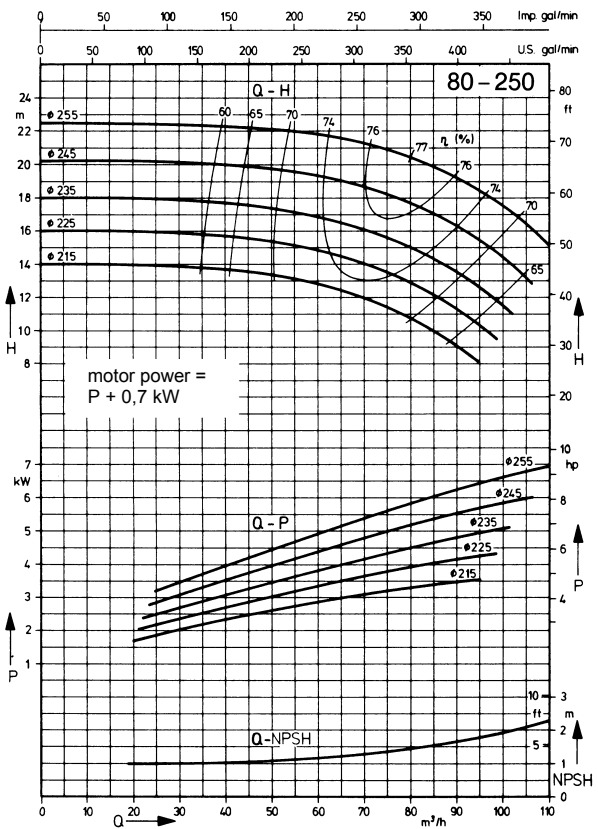
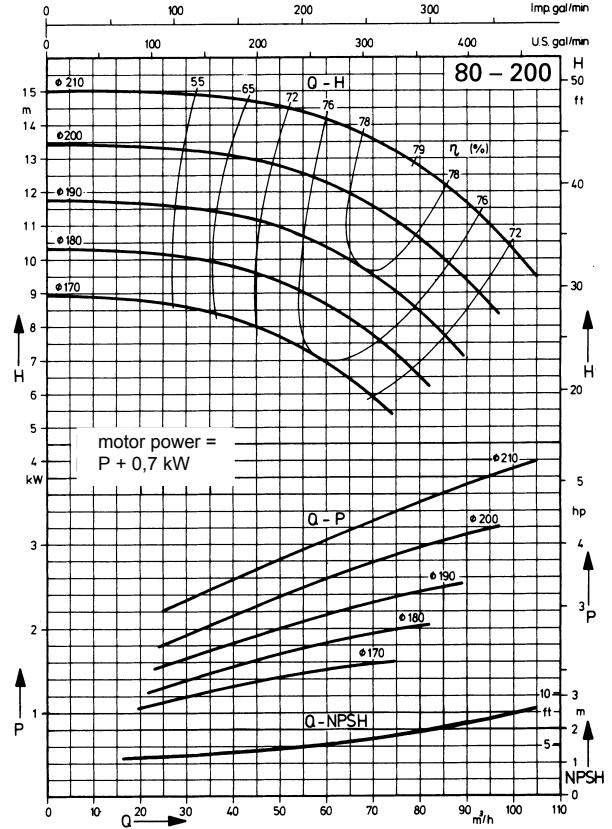
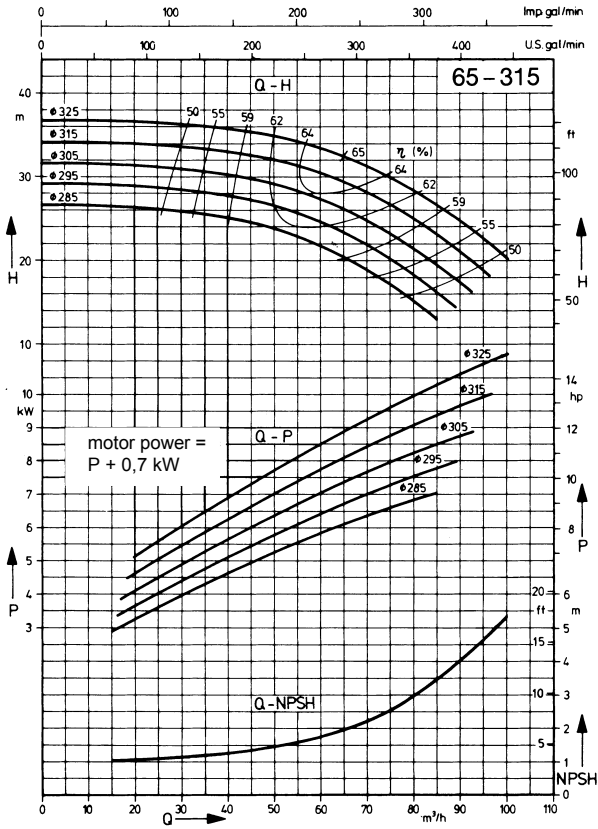

Characteristic curves

n = 1450 rpm

Attention: On selecting the motors, the constant drive power of the pertinent suction stage has to be added to the drive values determined out of the characteristic curves

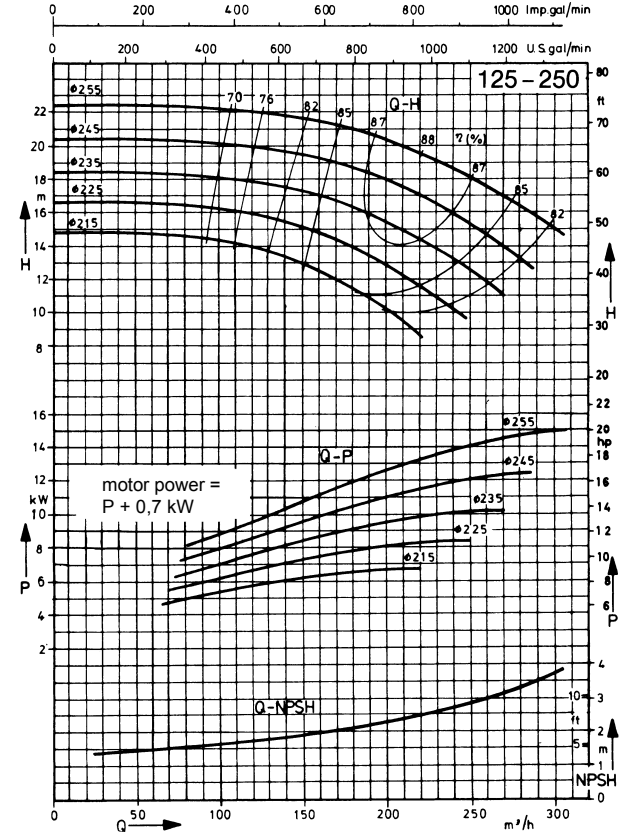
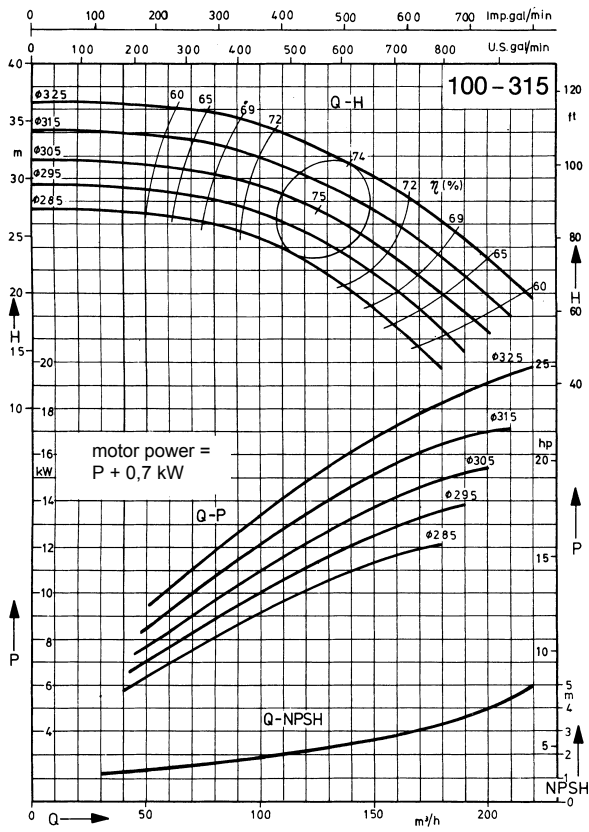
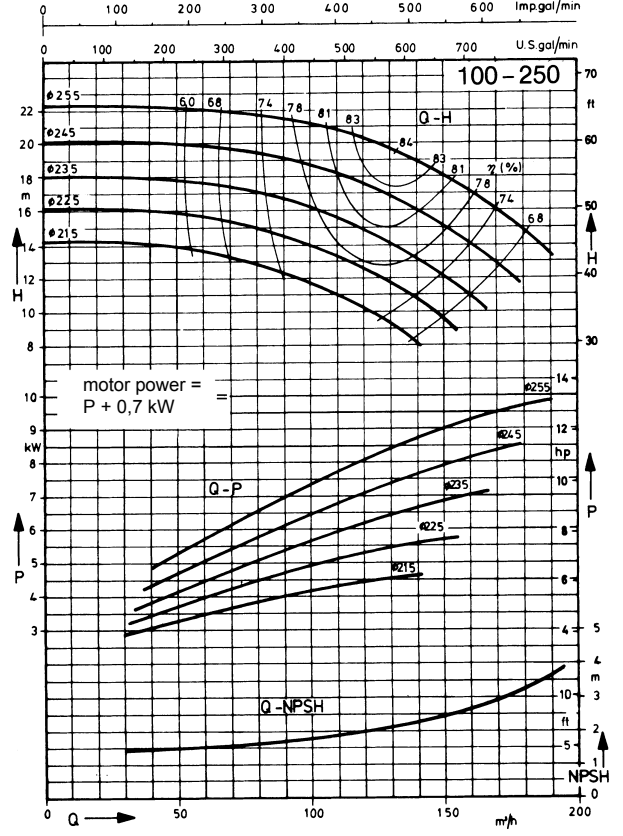
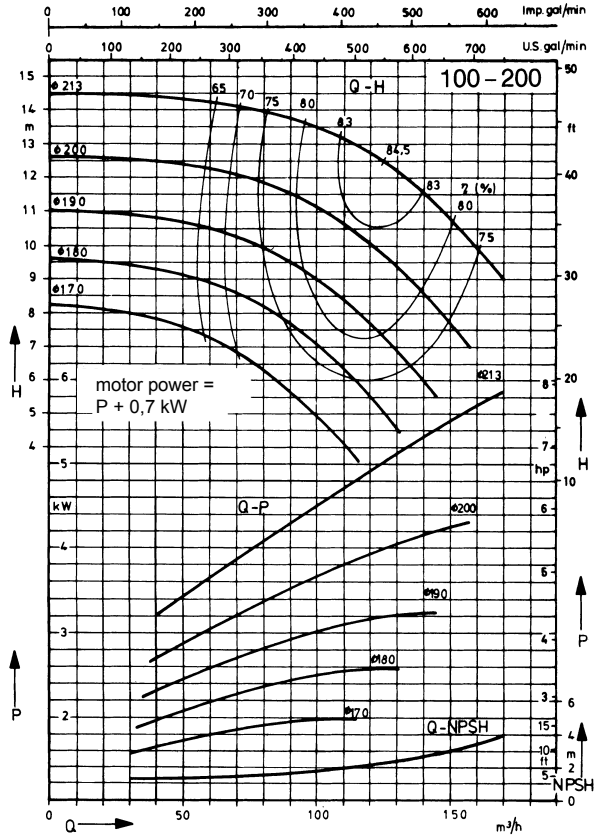

Description:

..... piece

VOLUTE CASING PUMPS
self-priming, acc. to DIN 24255

Make: Sterling SIHI

For handling of pure respectively turbid not aggressive liquids which do not contain solids.

Volute casing, casing cover and stage casing of GG-25 respectively cast tin bronze*, impeller of GG-25 respectively cast tin bronze*, vane wheel impeller of brass, shaft of 13% chrome steel with shaft seal by not balanced single standard mechanical seal of material combination Cr Ni/carbon, Perbunan resp. Viton for the following operation data:

*Please delete which is inapplicable

Liquid to be handled:
Temperature:	°C
Capacity Q	m ³ /h
Delivery head H	m
Power absorption of the pump	kW
Speed n	1/min
Motor power	kW

Scope of delivery: pump unit complete, i.e. pump incl. three-phase AC motor 220 VΔ resp. 380 VΔ, 50 Hz, protection type IP 54, incl. common base plate for pump and motor with flexible coupling.

Price for piece DM

Weight per piece kg

Dimension table

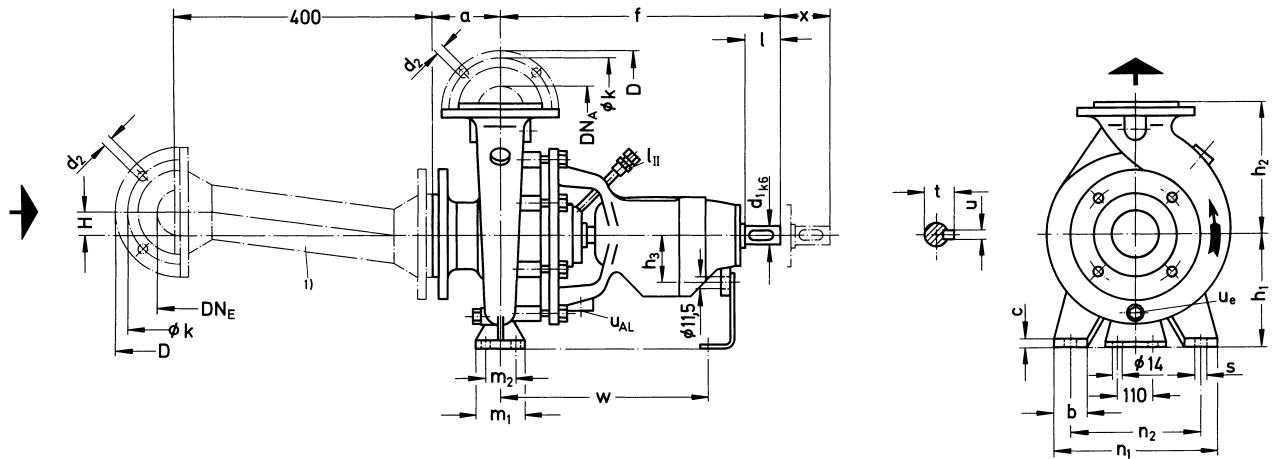

l_{II} = connection for air ventilation pipe G 3/8
 U_{AL} = connection for leak liquid G 1/4
 u_e = connection for discharge G 1/4 from DN_A 65 G 3/8

1) Pipe bend can be delivered as accessory by the factory.

size	DN_A	DN_E	a	b	c	f	H	h_1	h_2	h_3	m_1	m_2	n_1	n_2	s	w	x	d_1	l	t	u									
32-125	32	50	80	50	15	360	25	112	140	73	100	70	190	140	15	267	80	24	50	27	8									
32-160								132	160				240	190																
32-200								160	180																					
32-250								180	225				125	95								320	250	342	100	32	80	35	10	
40-125	40	65	80	50	15	360	25	112	140	73	100	70	210	160	15	267	80	24	50	27	8									
40-160								132	160				240	190																
40-200								160	180				265	212																
40-250								180	225				125	95								320	250	340	100	32	80	35	10	
40-315								225	250				87	345								280	340	100	32	80	35	10		
50-125								50	65				80	50								15	360	25	132	160	73	100	70	240
50-160	160	180	265	212																										
50-200	180	225	125	95	320	250	340			100	32	80			35	10														
50-200	200																													
50-315	225	280	87	345	280	340	100			32	80	35			10															
65-125	65	80	100	50	15	360	40			160	180	73			100	70	280	212	15	267	80				24	50				27
65-160								200																						
65-200								180	225	320	250																			
65-250								200	250	87	160		120	360			280	19				340	32	80			35	10		
65-315								225	280	87	160		120	400			315	19				340	32	80			35	10		
80-160								80	100	65	15		360	50			180	225				73	125	95			320	250	15	
80-200	250	87	345	280	340	32	80					35			10															
80-250	200	280	160	120	400	315	19					340			32	80		35	10											
80-315	250	315	160	120	400	315	19					340			32	80		35	10											
100-200	100	125	100	15	360	50	180	225	73	125	95	320	250	15	267	80	24	50	27	8										
100-250								225																						
100-315								250	315			160	120								400	315	19	340	32	80	35	10		
125-250	125	150	100	50	15	360	75	200	280	125	95	320	250	15	267	80	24	50	27	8										

Flange connections acc. to DIN 2501 PN 16 and PN 10

DN_A/DN_E	32	40	50	65	80	100	125	150
D	140	150	165	185	200	220	250	285
k	100	110	125	145	160	180	210	240
d_2 x number	18x4	18x4	18x4	18x4	18x8	18x8	18x8	22x8

Foundation plan

n = 2900 rpm

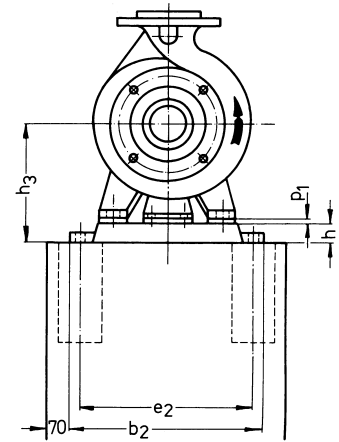
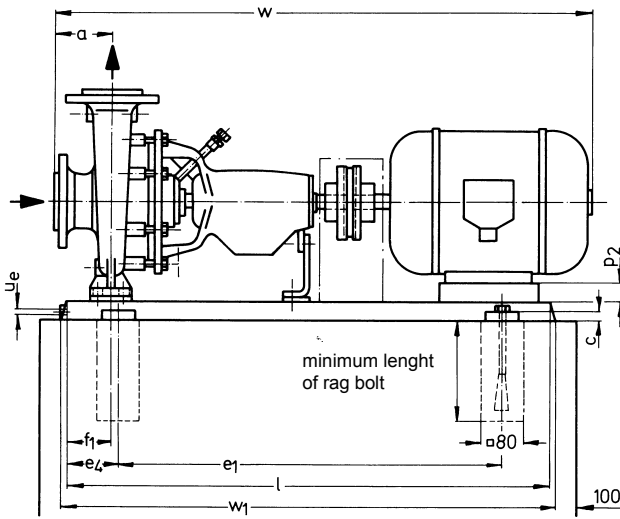

Dimensions in mm, tolerances (base plates) for cast pieces DIN 1686/GTB 17, for welded pieces acc. to DIN 8570 B

size	motor		base plate Nr.	coup- ling	weight		a	b ₂	c	e ₁	e ₂	e ₄	f ₁	h	h ₃	l	p ₁	p ₂	w*	w ₁	u _e	rag bolt DIN 529			
	size	kW			pump **kg	unit kg																			
32-125	71 b	0,55	P 241	A 10	23	52	80	330	25	480	290	115	60	65	177	710	-		41	678	730	G1/2	M 16 x 200		
	80 a	0,75				55																		32	687
	80 b	1,1				56																			702
	90 S	1,5				59																		22	742
	90 L	2,2				63																			767
32-160	80 b	1,1	P 272	A 25	26	59	80	360	540	320	130	75	80	197	710	-		52	702	820	G1/2	M 16 x 200			
	90 S	1,5				63																	42	742	
	90 L	2,2				67																		767	
	100 L	3,0				77																		800	
	112 M	4,0				95																	20	826	
32-200	90 L	2,2	P 272	A 10	30	71	80	330	480	290	115	75	80	225	710	-		70	767	730	G1/2	M 16 x 200			
	100 L	3,0				81																		800	
	112 M	4,0				99																		826	
	13S	5,5				117																	28	909	
	132 S	7,5				120																		909	
32-250	132 S	7,5	P 342	A 63	48	148	100	450	30	540	400	130	75	80	260	800	-		48	929	820	G1/2	M 20 x 200		
	160 M	11,0				207																		20	1094
	160 M	15,0				209																			1094
40-125	80 b	1,1	P 241	A 10	24	57	80	330	25	480	290	115	60	65	177	710	-		32	702	730	G1/2	M 16 x 200		
	90 S	1,5				61																		22	742
	90 L	2,2				65																			767
	100 L	3,0				74																		12	826
	100 L	3,0				74																			800
40-160	90 S	1,5	P 241	A 10	27	64	80	330	480	290	115	75	80	197	710	-		42	742	730	G1/2	M 16 x 200			
	90 L	2,2				68																		767	
	100 L	3,0				78																	32	826	
	112 M	4,0				96																	20	826	
	132 S	5,5				113																		909	
40-200	100 L	3,0	P 272	A 25	34	85	100	360	540	320	130	75	80	225	710	-		60	846	820	G1/2	M 16 x 200			
	112 M	4,0				103																	48	846	
	132 S	5,5				121																	28	929	
	132 S	7,5				124																		929	
	160 M	11,0				198																		1094	
40-250	132 S	7,5	P 344	A 63	42	156	100	450	30	660	400	170	75	80	240	1000	-		48	929	1020	G1/2	M 20 x 200		
	160 M	11,0				207																		20	1094
	160 M	15,0				209																			1094
	160 L	18,5				232																			1138
50-125	90 S	1,5	P 241	A 10	26	63	100	330	25	480	290	115	60	65	197	710	-		42	762	730	G1/2	M 16 x 200		
	90 L	2,2				67																			787
	100 L	3,0				77																		32	846
	112 M	4,0				95																		20	846
	132 S	5,5				112																			929
50-160	90 L	2,2	P 301	A 10	31	77	100	390	480	350	115	75	80	240	1000	-		70	787	730	G1/2	M 16 x 200			
	100 L	3,0				82																	360	60	846
	112 M	4,0				100																		846	
	132 S	5,5				118																	28	929	
	132 S	7,5				121																		929	
50-200	160 M	11,0	P 344	A 63	43	195	100	450	30	540	130	75	80	225	800	-		-	1094	1020	G1/2	M 20 x 200			
	100 L	3,0				87																		846	
	112 M	4,0				105																	48	846	
	132 S	5,5				134																	28	929	
	132 S	7,5				137																		929	
50-250	160 M	11,0	P 344	A 10	43	199	100	450	30	660	170	75	80	240	1000	-		-	1094	1020	G1/2	M 20 x 200			
	160 M	15,0				201																		1094	
	160 M	11,0				208																	20	1094	
	160 M	15,0				210																		1094	
	160 L	18,5				233																		1138	
50-250	180 M	22,0	S 385	A 100	43	292	100	490	40	740	440	190	110	290	1120	-		-	1165	-	-	G1/2	M 20 x 200		
	200 L	30,0				388																			1263

Foundation plan

n = 2900 rpm

size	motor		base plate Nr.	coup- ling	weight		a	b ₂	c	e ₁	e ₂	e ₄	f ₁	h	h ₃	l	p ₁	p ₂	w*	w ₁	U _e	rag bolt DIN 529												
	size	kW			pump kg	unit kg																												
65-125	100 L	3,0	P 342	A 10	29	95	100	450	30	540	400	130	75	80	240	800	-	60	846	820	G1/4	M 20 x 200												
	112 M	4,0		A 25		113													846															
	132 S	5,5	P 303	A 63		127													390				25	600	350	150	65	225	900	-	28	929	920	929
	132 S	7,5				130																										929		
65-160	132 S	5,5	P 344	A 63	34	132	450	30	660	400	170	80	240	1000	-	-	-	1094	1020	-	-	M 20 x 200												
	132 S	7,5				135												1094																
	160 M	11,0				198												1094																
65-200	160 M	15,0	S 385	A 100	38	200	490	40	740	440	190	110	290	1120	-	-	-	20	1094	-	-	-												
	160 M	11,0				203												1094																
	160 M	15,0				205												1094																
	160 L	18,5				228												1138																
	180 M	22,0				287												1165																
65-250	200 L	30,0	S 386	A 160	62	382	490	40	740	440	190	90	110	290	310	1120	-	20	1263	-	-	-												
	160 L	18,5				289													1248															
	180 M	22,0				311													1275															
	200 L	30,0				417													1373															
80-160	200 L	37,0	S 486	A 160	62	427	610	40	740	440	190	90	106	325	1120	-	-	-	1373	-	-	-												
	225 M	45,0				510													1432															
	132 S	7,5				144													954															
	160 M	11,0				203													1119															
	160 M	15,0				205													1119															
80-200	160 L	18,5	S 385	A 100	39	228	490	40	740	440	190	75	80	260	800	-	-	-	1163	1020	-	-												
	180 M	22,0				287													1190															
	160 M	15,0				260													1229															
	160 L	18,5				283													1273															
	180 M	22,0				305													1300															
80-250	200 L	30,0	S 386	A 160	56	411	490	40	740	440	190	110	290	1120	-	-	-	20	1398	-	-													
	200 L	37,0				421												1398																
	180 M	22,0				319												1398																
	200 L	30,0				424												1398																
	200 L	37,0				434												1398																
80-250	225 M	45,0	S 486	A 160	69	504	610	40	740	440	190	90	106	325	1120	-	-	-	1457	-	-	-												
	250 M	55,0				611													1577															
	200 L	30,0				424													1398															
	200 L	37,0				434													1398															
	225 M	45,0				504													1457															
100-200	250 M	55,0	S 487	A 250	65	611	610	40	740	440	190	106	325	1400	-	-	-	58	1577	-	-													
	160 L	18,5				299												1273																
	180 M	22,0				314												1300																
	200 L	30,0				420												1398																
	200 L	37,0				430												1398																
100-250	225 M	45,0	S 486	A 160	78	503	610	40	740	440	190	110	310	1120	-	-	-	33	1457	-	-													
	200 L	30,0				440												1413																
	200 L	37,0				450												1413																
	225 M	45,0				525												1472																
	250 M	55,0				621												1592																
100-250	280 S	75,0	S 607	PKZ 17 **	78	822	610	40	740	440	190	106	350	1400	-	-	-	55	1676	-	-													
	280 M	90,0				868												1727																
	280 M	90,0				868												1727																

* motors-type of enclosure IP 54, dimensions dependent on motor make

** PKZ-coupling dynamically balanced

Foundation plan

n = 1450 rpm

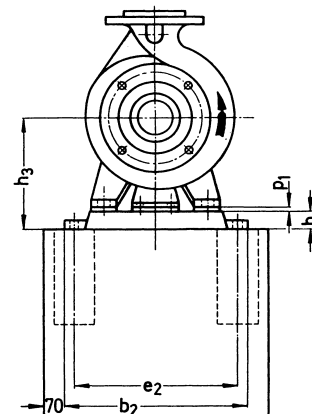
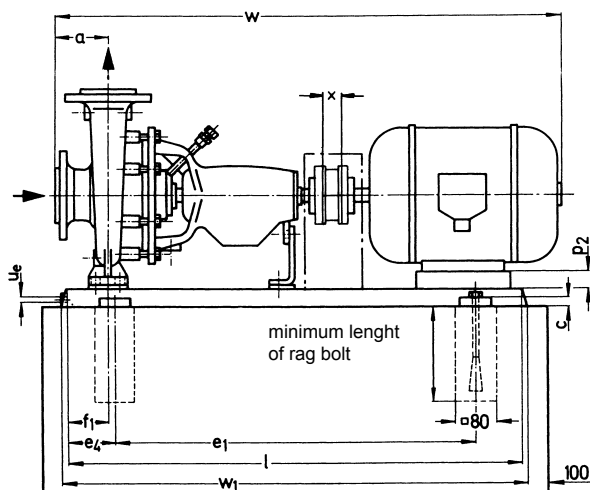

Dimensions in mm, tolerances (base plates) for cast pieces acc. to DIN 1686/GTB 17, for welded pieces acc. to DIN 8570 B

size	motor size	motor kW	base plate Nr.	coupling	pump weight kg	unit weight kg	a	b ₂	c	e ₁	e ₂	e ₄	f ₁	h	h ₃	l	p ₂	w*	w ₁	u _e	rag bolt DIN 529	
32-250	80 b	0,75	P 342	A 10	40	92	100	450	30	540	400	130	60	80	260	800	100	722	820	G1/2	M 20 x 200	
	90 S	1,1				96											90	762				
	90 L	1,5		100		80											787					
	100 L	2,2		108		80											846					
40-250	90 S	1,1	P 342	A 10	42	99	100	450	30	540	400	130	73	80	260	800	90	762	820	G1/2	M 20 x 200	
	90 L	1,5				103											80	787				
	100 L	2,2		110		80											846					
	100 L	3,0		111		80											846					
40-315	100 L	2,2	P 383	A 25	78	153	125	490	600	440	150	75	305	900	900	125	981	920	G1/2	M 20 x 200		
	100 L	3,0				154										113	981					
	112 M	4,0		172		93										1064						
	132 S	5,5		194		93										1064						
50-250	90 L	1,5	P 342	A 10	43	104	100	450	30	540	400	130	75	80	260	800	90	787	820	G1/2	M 20 x 200	
	100 L	2,2				111											80	846				
	100 L	3,0		112		80											846					
	112 M	4,0		130		68											846					
50-315	112 M	4,0	P 383	A 63	80	174	125	490	600	400	150	190	110	335	1120	113	981	920	G1/2	M 20 x 200		
	132 S	5,5				196										93	1064					
	132 M	7,5		246		93										1064						
	132 M	7,5		246		110										1102						
65-250	100 L	2,2	P 383	A 25	62	137	100	490	30	600	440	150	90	80	280	900	100	956	920	G1/2	M 20 x 200	
	100 L	3,0				136											88	956				
	112 M	4,0		156		88											956					
	132 S	5,5		216		68											1039					
65-315	132 S	5,5	S 385	A 63	87	242	125	490	40	740	190	110	310	335	1120	93	1064	-	-	-	-	
	132 M	7,5				252										65	1102					
	160 M	11,0		297		65										1229						
	160 L	15,0		318		65										1273						
80-200	90 L	1,5	P 383	A 25	56	122	125	490	30	600	440	150	75	80	260	900	90	922	920	G1/2	M 20 x 200	
	100 L	2,2				130											68	981				
	100 L	3,0		131		68											981					
	112 M	4,0		149		48											1064					
80-250	132 S	5,5	S 385	A 63	69	170	125	490	40	740	190	100	110	310	1120	100	981	-	-	-	-	
	112 M	4,0				203										88	981					
	132 S	5,5		224		68										1064						
	132 M	7,5		234		68										1064						
80-315	132 S	5,5	S 385	A 63	92	248	125	490	40	740	190	100	110	360	1120	118	1064	-	-	-	-	
	132 M	7,5				258										118	1102					
	160 M	11,0		302		90										1229						
	160 L	15,0		323		90										1273						
100-200	100 L	2,2	P 383	A 25	65	137	125	490	30	600	440	150	90	80	280	900	100	981	920	G1/2	M 20 x 200	
	100 L	3,0				140											88	981				
	112 M	4,0		159		68											1064					
	132 S	5,5		220		68											1064					
100-250	132 M	7,5	S 385	A 63	78	230	140	490	40	740	190	100	110	310	1120	113	996	-	-	-	-	
	112 M	4,0				212										113	996					
	132 S	5,5		234		93										1079						
	132 M	7,5		244		65										1117						
100-315	160 M	11,0	S 385	A 100	97	288	140	490	40	740	440	190	100	110	360	1120	90	1244	-	-	-	-
	160 M	11,0				307											90	1244				
	180 M	18,5		348		70											1315					
	180 L	22,0		369		70											1353					
125-250	132 M	7,5	S 385	A 63	97	263	140	490	40	740	440	190	100	110	360	1120	118	1117	-	-	-	M 20 x 200
	160 M	11,0		A 100		307											90	1244				
	160 L	15,0		A 100		328											90	1288				

* motors-type of enclosure IP 54, dimensions dependent on motor make

Foundation plan for units with spacer type coupling

n = 2900 rpm

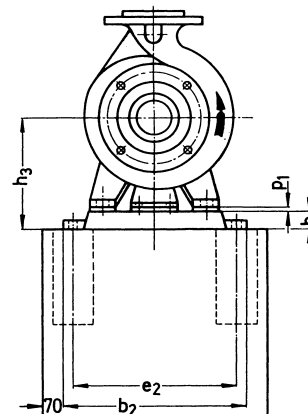
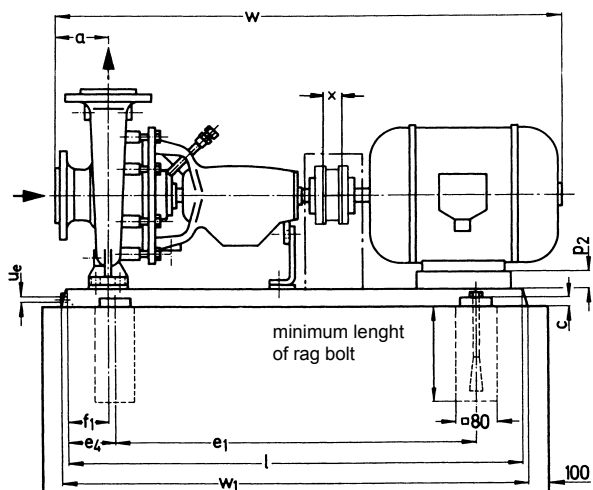

Dimensions in mm, tolerances (base plate) for cast pieces acc. to DIN 1686/GTB 17, for welded pieces acc. to DIN 8570 B

size	motor size	kW	base plate Nr.	coupling PKA	weight pump kg	unit kg	a	b ₂	c	e ₁	e ₂	e ₄	f ₁	h	h ₃	l	p ₁	p ₂	w*	w ₁	u _e	x	rag bolt DIN 529										
32-125	71 b	0,55	P 241	8	23	55	80	330	25	480	290	115	50	65	177	710	-	41	794	730	G1/2	100	M 16 x 160										
	80 a	0,75	P 272			62													360	540				320	160	60	32	820	820				
	80 b	1,1				63																					22	850	880				
	90 S	1,5				67																											
	90 L	2,2				71																											
32-160	80 b	1,1		26	67	70									197																		
	90 S	1,5																							74						52	820	820
	90 L	2,2																							77						42	850	880
	100 L	3,0																							80								
	112 M	4,0	P 303																						108	390	600	350	150	60	32	930	920
32-200	90 L	2,2	P 272	30	79	85		360		540	320	130	50		225	800																	
	100 L	3,0																							113	390	600	350	150	60	70	880	820
	112 M	4,0	P 303																						128						60	930	920
	132 S	5,5																							132						48	940	920
32-250	132 S	7,5	P 344	9	48	173	100	450	30	660	400	170	75	80	260	1000																	
	160 M	11,0																							214						48	1090	1020
	160 M	15,0																							218						20	1200	
40-125	80 b	1,1	P 272	8	24	64	80	360	25	540	320	130	60	65	177	800																	
	90 S	1,5				68																								32	820	820	
	90 L	2,2				72																								22	850	880	
	100 L	3,0				78																								12	930		
	90 S	1,5				71																								50			
40-160	90 L	2,2		27	75	84									197																		
	100 L	3,0																							84						50		
	112 M	4,0	P 303																						109	390					60		
	132 S	5,5																							124								
	100 L	3,0	P 272																						89	100	360				50		
40-200	112 M	4,0	P 303	9	117	132		390		540	320	130	60		225	800																	
	132 S	5,5																							136						60	950	820
	132 S	7,5																							200						48	960	920
	160 M	11,0	P 344																						217						28	1030	
	132 S	7,5																							157								
40-250	160 M	11,0		42	208	212				660	400	170	75	80	240	1000																	
	160 M	15,0																							212						48	1030	1020
	160 L	18,5	S 385																						272						20	1200	
	100 L	3,0	P 272																						89	100	360				50		
	112 M	4,0	P 303																						117								
50-125	90 S	1,5	P 272	8	26	70	360	25	540	320	130	60	65	197	800																		
	90 L	2,2				74																								42	870	820	
	100 L	3,0				80																								32	950		
	112 M	4,0	P 303			108																			390	600	350	150	60	20	960	920	
	132 S	5,5				123																											
50-160	90 L	2,2	P 272	31	80	86		360		540	320	130	50		225	800																	
	100 L	3,0																							86								
	112 M	4,0	P 303																						114	390	600	350	150	60	70	900	820
	132 S	5,5																							129						60	950	920
	132 S	7,5																							133						48	960	920
50-200	160 M	11,0	P 344	9	197					660	400	170		80	240	1000																	
	100 L	3,0	P 272																						92	360	540	320	130	50	65	225	800
	112 M	4,0	P 303																						118	390	600	350	150	60			
	132 S	5,5																							133						48	960	920
	132 S	7,5																							137						28	1030	
50-250	160 M	11,0	P 344	10	201	204		450	30	660	400	170		80	240	1000																	
	160 M	15,0																							213								
	160 M	11,0																							213								
	160 M	15,0																							273								
	180 M	22,0																							297								
50-250	160 M	11,0		9	209	213									260																		
	160 M	15,0																						213									
	160 M	11,0																						273									
	160 M	15,0																						297									
	200 L	30,0	P 436																					383	490	40	740	440	190		110	290	1120
50-250	160 M	11,0		12	297	383																											
	160 M	15,0																						297									
	160 M	11,0																						297									
	160 M	15,0																						383									
	200 L	30,0	P 436																					383	540	30	840	490	205		80	280	1250
50-250	160 M	11,0		12	297	383																											
	160 M	15,0																						297									
	160 M	11,0																						297									
	160 M	15,0																						383									
	200 L	30,0	P 436																					383	540	30	840	490	205		80	280	1250
50-250	160 M	11,0		12	297	383																											
	160 M	15,0																						297									
	160 M	11,0																						297									
	160 M	15,0																						383									
	200 L	30,0	P 436																					383	540	30	840	490	205		80	280	1250
50-250	160 M	11,0		12	297	383																											
	160 M	15,0																						297									
	160 M	11,0																						297									
	160 M	15,0																						383									
	200 L	30,0	P 436																					383	540	30	840	490	205		80	280	1250
50-250	160 M	11,0		12	297	383																											
	160 M	15,0																						297									
	160 M	11,0																						297									
	160 M	15,0																						383									
	200 L	30,0	P 436																					383	540	30	840	490	205		80	280	1250
50-250	160 M	11,0		12	297	383																											
	160 M	15,0																						297									
	160 M	11,0																						297									
	160 M	15,0																						383									
	200 L	30,0	P 436																					383	540	30	840	490	205		80	280	1250
50-250	160 M	11,0		12	297	383																											
	160 M	15,0																						297									
	160 M	11,0																						297									
	160 M	15,0																						383									
	200 L	30,0	P 436																					383	540	30	840	490	205		80		

Foundation plan for units with spacer type coupling

n = 2900 rpm

size	motor size	motor kW	base plate Nr.	coupling PKA	weight pum p kg	weight unit kg	a	b ₂	c	e ₁	e ₂	e ₄	f ₁	h	h ₃	l	p ₁	p ₂	w*	w ₁	u _e	x	rag bolt DIN 529				
65-125	100 L	3,0	P 303	8	29	95	100	390	25	600	350	150	75	65	225	900	-	60	950	920	G1/2	100	M 16 x 160				
	112 M	4,0				112												48	965								
	132 S	5,5				127												28	1030								
	132 S	7,5				131																					
65-160	132 S	5,5	P 344	8	34	132	450	30	660	400	170	65	80	240	1000	-	-	-	1200	1020	-	-	M 20 x 250				
	132 S	7,5				139																					
	160 M	11,0				200																					
	160 M	15,0				204																					
65-200	160 M	11,0	S 385	9	38	204	490	40	740	440	190	75	110	290	1120	-	-	-	-	-	-	-	-	M 20 x 250			
	160 L	18,5				269																					
	180 M	22,0				292																					
	200 L	30,0				378																					
65-250	160 L	18,5	S 386	10	62	402	490	40	-	440	-	90	110	310	-	-	-	-	-	-	-	-	-	M 24 x 400			
	180 M	22,0				326																					
	200 L	30,0	S 487	12	-	-	-	-	-	-	-	-	-	-	-	-	-	-	-	-	-	-	-	-			
	200 L	37,0																							416		
	225 M	45,0																							430		
225 M	45,0		15	512																							
80-160	132 S	7,5	P 344	9	39	154	125	450	30	660	400	170	65	80	260	1000	-	48	1055	1020	G1/2	-	-	M 20 x 250			
	160 M	11,0				205																					
	160 M	15,0				209																					
	160 L	18,5				269																					
80-200	160 M	15,0	S 386	10	56	263	490	40	740	440	190	75	110	290	1120	-	-	-	-	-	-	-	-	M 24 x 400			
	160 L	18,5				296																					
	180 M	22,0				320																					
	200 L	30,0				410																					
80-250	180 M	22,0	S 486	12	69	424	610	-	-	-	-	90	-	-	-	-	-	-	-	-	-	-	-	M 24 x 400			
	200 L	30,0				437																					
	200 L	37,0	S 487	14	-	-	-	-	-	-	-	-	-	-	-	-	-	-	-	-	-	-	-	-			
	225 M	45,0																							519		
	250 M	55,0																							650		
100-200	160 L	18,5	S 386	12	65	312	490	-	-	-	-	-	110	310	1250	-	-	-	-	-	-	-	-	M 20 x 250			
	180 M	22,0				322																					
	200 L	30,0				422																					
	200 L	37,0				435																					
	225 M	45,0				518																					
100-250	200 L	30,0	S 487	14	78	435	610	-	-	-	-	-	100	300	1400	-	-	-	-	-	-	-	-	M 24 x 400			
	200 L	37,0				448																					
	225 M	45,0				531																					
	250 M	55,0				661																					
	280 S	75,0				842																					
	280 M	90,0				892																					

* motor-type of enclosure IP 54, dimensions dependent on motor make

Foundation plan for units with spacer type coupling

n = 1450 rpm

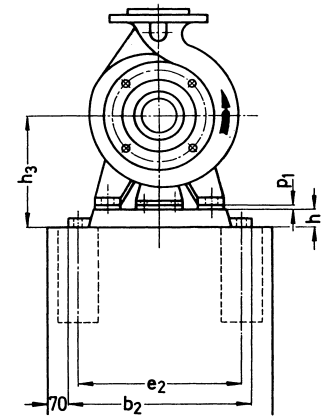
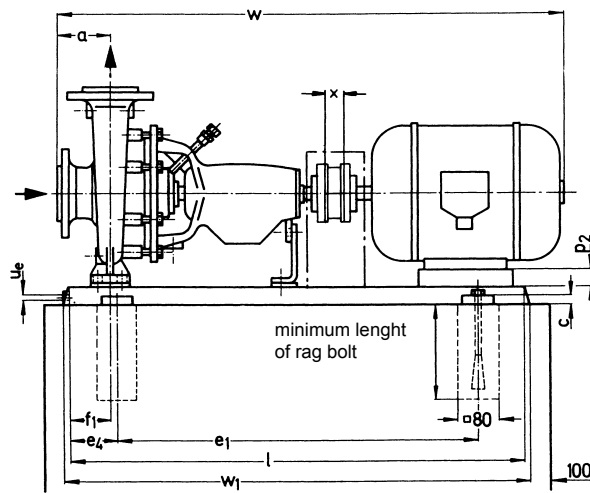

Dimensions in mm, tolerances (base plate) for cast pieces acc. to DIN 1686/GTB 17, for welded pieces acc. to DIN 8570 B

size	motor size	motor kW	base plate Nr.	coupling PKA	pump weight kg	unit weight kg	a	b ₂	c	e ₁	e ₂	e ₄	f ₁	h	h ₃	l	p ₂	w*	w ₁	u _e	x	rag bolt DIN 529
32-250	80 b	0,75	P 342	8	40	100	100	450	30	540	400	130	75	80	260	800	100	840	820	G1/2	100	M 20 x 250
	90 S	1,1				104											870					
	90 L	1,5	108			895																
	100 L	2,2	118			950																
40-250	90 S	1,1	P 342	8	42	106	100	450	30	540	400	130	75	80	260	800	90	870	820	G1/2	100	M 20 x 250
	90 L	1,5				110											870					
	100 L	2,2	122			985																
	100 L	3,0	125			950																
40-315	100 L	2,2	S 385	9	78	174	125	490	40	740	440	150	75	110	335	1120	125	1080	-	-	-	-
	100 L	3,0				177											1080					
	112 M	4,0	196			1130																
	132 S	5,5	211			1165																
50-250	90 L	1,5	P 342	8	43	111	100	450	30	540	400	130	75	80	260	900	90	895	920	G1/2	100	M 20 x 250
	100 L	2,2				123											895					
	100 L	3,0	126			950																
	112 M	4,0	145			1000																
50-315	112 M	4,0	S 385	9	80	225	125	490	40	740	440	150	75	110	335	1120	113	1090	-	-	-	-
	132 S	5,5				235											1165					
	132 M	7,5	253			1200																
	132 S	5,5	253			1200																
65-250	100 L	2,2	P 343	8	62	155	100	540	30	660	490	170	90	80	280	1000	100	1060	1020	G1/2	100	M 20 x 250
	100 L	3,0				158											1070					
	112 M	4,0	176			1140																
	132 S	5,5	221			1200																
65-315	132 S	5,5	S 385	9	87	241	125	490	40	740	440	190	90	110	310	1120	68	1140	-	-	-	-
	132 S	5,5				241											1165					
	132 M	7,5	258			1200																
	160 M	11,0	310			1330																
80-200	90 L	1,5	P 434	8	56	128	125	540	30	660	490	170	75	80	260	1000	90	1035	1020	G1/2	100	M 20 x 250
	100 L	2,2				146											1080					
	100 L	3,0	148			1080																
	112 M	4,0	169			1090																
80-250	132 S	5,5	S 385	9	69	184	125	490	40	740	440	190	90	110	310	1120	48	1165	-	-	-	-
	100 L	3,0				164											1080					
	112 M	4,0	183			1090																
	132 S	5,5	219			1165																
80-315	132 M	7,5	S 385	10	92	235	125	490	40	740	440	190	90	110	310	1120	118	1165	-	-	-	-
	132 S	5,5				245											1165					
	132 M	7,5	263			1200																
	160 M	11,0	311			1330																
100-200	100 L	2,2	P 434	8	65	163	125	540	30	660	490	170	90	80	280	1000	100	1125	1020	G1/2	140	M 20 x 250
	100 L	3,0				166											1200					
	112 M	4,0	203			1245																
	132 S	5,5	218			1260																
100-250	132 M	7,5	S 385	10	78	238	140	490	40	740	440	190	90	110	310	1120	113	1150	-	-	-	-
	112 M	4,0				220											1150					
	132 S	5,5	235			1220																
	132 M	7,5	253			1260																
100-315	160 M	11,0	S 386	12	97	305	140	490	40	740	440	190	90	110	360	1120	65	1390	-	-	-	-
	160 M	11,0				321											1430					
	160 L	15,0	346			1460																
	180 M	18,5	370			1500																
125-250	132 M	7,5	S 385	10	97	273	140	490	40	740	440	190	90	110	360	1120	118	1260	-	-	140	M 20 x 250
	160 M	11,0	S 386	12	97	321	140	490	40	840	440	205	90	110	360	1250	90	1390	-	-	140	M 20 x 250
	160 L	15,0		15	97	347	140	490	40	840	440	205	90	110	360	1250	90	1430	-	-	140	M 20 x 250

Data regarding size - order notes

Series + size	Hydraulic+ bearing	Shaft seal	Material design	Casing seal
	A' speed n = 1450 rpm B' speed n = 2900 rpm 'B' two greased antifriction bearing	AAE standard mechanical seal O-rings Perbunan AA1 as per AAE, but O-rings Viton	0A standard design cast iron 0C as per 0A, but impeller of G-CuSn 10 3B main parts of G-CuSn 10	2 flat seals
ULN	32-125	BB	alternatively 0A 0C 3B	2
	32-160	BB		
	32-200	BB		
	32-250	AB		
	32-250	BB		
	40-125	BB		
	40-160	BB		
	40-200	BB		
	40-250	AB		
	40-250	BB		
	40-315	AB		
	50-125	BB		
	50-160	BB		
	50-200	BB		
	50-250	AB		
	50-250	BB		
	50-315	AB		
	65-125	BB		
	65-160	BB		
	65-200	BB		
	65-250	AB		
	65-250	BB		
	65-315	AB		
	80-160	BB		
	80-200	AB		
	80-200	BB		
80-250	AB			
80-250	BB			
80-315	AB			
100-200	AB			
100-200	BB			
100-250	AB			
100-250	BB			
100-315	AB			
125-250	AB			

Design	Designation	Selection table motors					
		motor n = 2900 rpm			motor n = 1450 rpm		
		kW	size	designation	kW	size	designation
pump with free shaft end	01						
pump with coupling, ready drilled at motor side and coupling guard for the shaft coupling	41	0,55	71 b	EA	0,25	71 a	DB
as above, but pump and coupling guard for the shaft coupling, mounted on base plate, incl. supports for pump and motor and 1 set of rag bolts	53	0,75	80 a	FA	0,37	71 b	EB
		1,1	80 b	GA	0,55	80 a	FB
		1,5	90 S	HA	0,75	80 b	GB
		2,2	90 L	JA	1,1	90 S	HB
		3,0	100 L	KA	1,5	90 L	JB
as above, but with motor e.g. 18,5 kW-three-phase AC motor (50 Hz, 380 V) at 2900 rpm	e.g. UA	4,0	112 M	MA	2,2	100 L	KB
		5,5	132 S	NA	3,0	100 L	LB
		7,5	132 S	OA	4,0	112 M	MB
		11	160 M	SA	5,5	132 S	NB
		15	160 M	TA	7,5	132 M	PB
		18,5	160 L	UA	11	160 M	SB
		22	180 M	VA	15	160 L	UB
		30	200 L	XA	18,5	180 M	VB
		37	200 L	YA	22	180 L	WB
		45	225 M	AA			
		55	250 M	BA			
		75	280 S	CA			
		90	280 M	DA			

Important:

In case of order please indicate always output Q [m³/h] and delivery head H [m].

Example for ordering:

The size ULN 65-250 BB AAE 0A 2 with coupling, pre-drilled at the motor side and coupling guard for the shaft coupling has the complete order number:

ULN · 65-250 BB AAE 0A 2 41

The size ULN 65-250 BB AAE 0A 2 as complete unit with 18,5 kW three-phase AC motor, 2900 rpm has the complete order number:

ULN · 65-250 BB AAE 0A 2 UA

On delivery, the period (·) at the fourth place of the type designation is replaced by a letter in the factory.

On ordering the designs 41 and 53 please indicate always the provided motor in order that the coupling can be ready drilled at motor side and choose the correct base plate and to enclose the proper documentation.

On request, the bearing bracket can be delivered in oil-lubricated design against additional costs-please indicate extra.

Any changes in the interest of the technical development are reserved.

Sterling SIHI GmbH

Lindenstraße 170, D-25524 Itzehoe, Germany, Telephone +49 (0)48 21 / 7 71 - 01, Fax +49 (0)48 21 / 7 71-274